

CHAPTER

5.0

GUIDE: STREET DESIGNS

The location and shape of curb lines exerts a strong influence on pedestrian comfort and usability of streets as public spaces. This chapter describes pedestrian-oriented guidelines for curb lines, crossings and other street design features to enhance pedestrian safety and comfort, and enable generous, usable public spaces

CHAPTER

5.0

STREET DESIGNS

- 5.1 Crosswalks
- 5.2 Corner Curb Radii
- 5.3 Curb Extensions
- 5.4 Medians and Islands
- 5.5 Transit-Supportive Streetscape Design
- 5.6 Parking Lane Treatments
- 5.7 Traffic Calming and Roundabouts
- 5.8 Pedestrian-Priority Designs



Marked crosswalks are an essential part of the pedestrian realm that enable safe, convenient pedestrian travel across roadways.

5.1 CROSSWALKS

Marked crosswalks are an essential part of the pedestrian realm that enable safe, convenient pedestrian travel across roadways. In special cases, they may also be a unique urban design treatment.

The California motor vehicle code requires drivers to yield to pedestrians in marked or unmarked crosswalks, but many drivers are unfamiliar with the details of the vehicle code. Marked crosswalks serve to alert drivers to expect crossing pedestrians and to direct pedestrians to desirable crossing locations. Ideally, crosswalks should be designed as a fundamental part of the pedestrian realm which motor vehicles cross into, rather than merely as a pedestrian intrusion into the domain ruled by drivers.

Placement

Crosswalks are present by law at all approximately right angle intersections, whether marked or unmarked, unless the pedestrian crossing is specifically prohibited. At mid-block locations, crosswalks only exist where marked. At these non-intersection locations, it is the crosswalk markings that legally establish the crosswalk. Most importantly, the decision to mark a crosswalk shouldn't be considered in isolation, but rather in conjunction with other measures to increase motorists' awareness of pedestrians. Crosswalks alone are unlikely to increase pedestrian safety without additional measures.



Controlled Intersections

Per existing City policy, marked crosswalks should be provided on all intersection legs controlled by traffic signals, unless pedestrian crossing is prohibited.

Crosswalks may be considered at all stop-controlled intersections. Legs controlled by stop signs should have marked crosswalks if ANY of the following are true:

- The crossing is located in a school zone or is used by substantial numbers of elderly or disabled (at least 20 in the peak hour of pedestrian demand)
- High numbers of pedestrians (existing or expected) or a desire to mark a key pedestrian route
- Vehicular daily volumes of 6,000 or more are expected to cross over the crosswalk
- Safety or efficiency reasons dictate directing pedestrians to a particular leg of the intersection.

Uncontrolled Intersections

Marked crosswalks may be considered at most crossing locations subject to engineering judgment. However, it is not feasible or necessary to mark crosswalks everywhere, and they should be prioritized to locations with highest need. Marked crosswalks should not be used without additional measures where the following conditions exist:

- High vehicular traffic volumes
- High vehicle speeds
- Wide roadways with multiple lanes
- Poor stopping sight distances
- Poor night time visibility
- Significant grades
- High pedestrian volumes

Thresholds for these factors are not hard and fast, and crosswalks may be marked where none of the factors give cause for concern, but where there is still a clear safety need to direct pedestrians and discourage use of unsafe alternatives.

High-Visibility Crosswalks

Because of the low approach angle at which pavement markings are viewed by drivers, the use of longitudinal stripes in addition to or in place of the standard transverse markings can significantly increase the visibility of a crosswalk to oncoming traffic. However, research has not shown a direct link between increased crosswalk visibility and increased safety or an increase in motorists yielding to pedestrians. A recent comparative study in San Francisco concluded that the presence of high visibility crosswalks at school crossings does not improve safety by itself.

In San Francisco, high visibility crosswalks are striped using the “continental” pattern and have been employed only at school crossings and mid-block locations. For consistency, and to avoid the over-proliferation and eventual dilution of the marking’s effectiveness, City policy has been to avoid exceptions to this rule.

Continental crosswalks cost four times standard crosswalks to install and maintain. Despite their added cost and the lack of hard evidence pointing to their safety benefits, many cities see continental or other similar high visibility markings as a relatively inexpensive way to improve the walking environment and send a message that pedestrians are present, and therefore use them at both controlled and uncontrolled crosswalks that are neither near schools nor mid-block locations yet still deserve extra attention.

High-visibility crosswalks should be used at all mid-block crossings and school crossings; they should be considered at crossings where conditions necessitate greater visibility.

The City has existing crosswalk guidelines; however, these guidelines have never been formally adopted. The City should refine and adopt these guidelines.

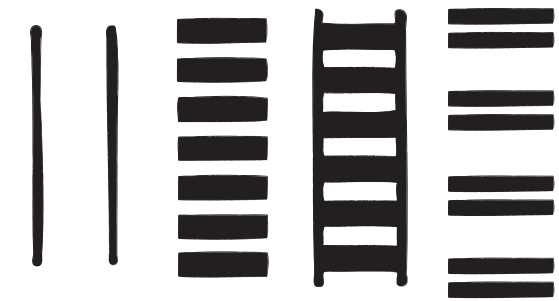

▲ Typical crosswalk markings. Left to right: Standard, Continental, Ladder, Staggered Continental

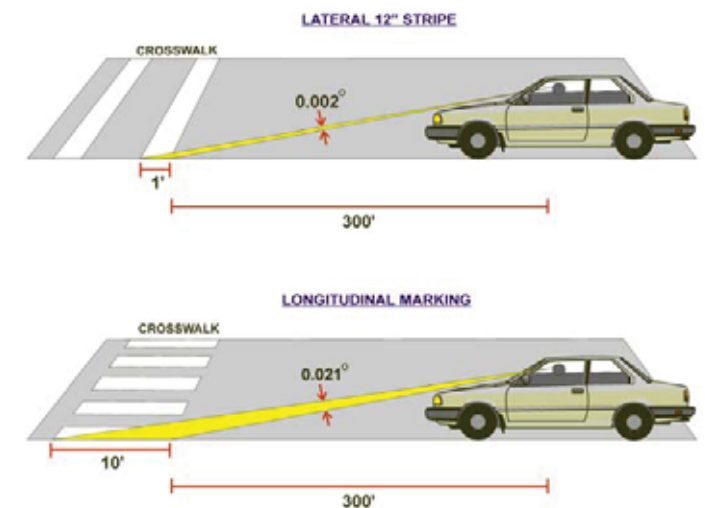

▲ Driver's view of crosswalk markings. Source: ITE Professional Development Complete Streets Webinar, 2008





The staggered continental crosswalk increases crosswalk visibility but positions stripes to avoid vehicle wheels, reducing maintenance burdens

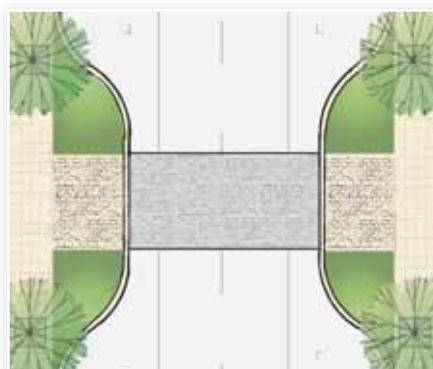

Mid-block crossings improve pedestrian convenience, especially on long blocks.



Mid-Block Crosswalks

Mid-block crosswalks provide convenient crossing locations for pedestrians when other crossing opportunities are distant, or where a destination creates high crossing demand. In areas with short block lengths, closely-spaced intersections ensure that pedestrians can easily find crosswalks without having to go out of their way. However, some areas have long blocks with widely-spaced intersections and fewer crossing opportunities.

Signalized mid-block crossings may complicate synchronization of traffic signals, and may increase delay for transit, especially on two-way streets.

Mid-block crosswalks should be considered at:

- Key civic and commercial locations
- Areas with major pedestrian attractors with mid-block entries like shopping areas, schools and community centers
- Mid-block transit stop locations
- Long blocks (generally > 500') with high expected pedestrian volumes

New mid-block crosswalks should generally only be marked if ALL of the following are true:

- The location is visible to motorists, allows for adequate stopping distance, and visibility is protected (e.g., by limiting on-street parking immediately adjacent to approaches to the crosswalks)
- Length of the block is no less than 400 feet
- Crosswalk is not less than 200 feet from the intersection
- At least 60 pedestrians are expected in the peak hour (of pedestrian demand)
- The crosswalk will be controlled by traffic signal or will have special warning devices (e.g. signs, signals, or flashing beacons)

In San Francisco, mid-block crosswalks must be established by resolution.

Design

Crosswalks should be at least as wide as the sidewalk, but may be wider in locations with high pedestrian demand or narrow sidewalks. Crosswalks should be no less than 10 feet in width. A more desirable width is 15 feet. Crosswalks must be outfitted with curb ramps and tactile warning strips per federal accessibility guidelines. The CA MUTCD contains standards and guidance on crosswalk warning signs and supplementary markings.

Standard Crosswalks

The standard treatment for marked crosswalks at intersection locations consists of two 12"-wide white retro-reflective thermoplastic stripes that delineate the sides of pedestrian walking area. These standard crosswalk stripes should be perpendicular (or transverse) to the direction of vehicle travel and parallel to the direction of pedestrian travel. School crosswalks must be yellow per state code; in San Francisco, school crossings should be given a high visibility crosswalk treatment.

High-Visibility Crosswalks

High-visibility crosswalks should be marked using the continental pattern of crosswalk striping, which consists of a series of wide stripes parallel to the curb for the length of the crossing. (These are distinguished from ladder crosswalks, which retain the transverse side stripes of the standard crosswalk in addition to the wide 'rungs' of the ladder, or zebra crosswalks, which have diagonal stripes. See diagram at right.)

In order to provide high-visibility crosswalks while minimizing increases to maintenance costs, the City should explore the use of a 'staggered continental' crosswalk striping, which staggers the gaps in the parallel crosswalk stripes and situates them to avoid vehicle wheel paths, reducing wear.

Mid-Block Crosswalks

Mid-block crossings should:

- Be enhanced through the use of signage, striping, signalization, or other special treatments such as flashing beacons, special paving materials, or raised crossings
- Be constructed in combination with mid-block curb

extensions wherever possible (see Curb Extensions, Section 5.3)

- Include pedestrian lighting oriented toward the crossing after dark.

Supplementary Pedestrian Crossing Treatments

Pedestrian Warning Signs

Pedestrian warning signs are used to alert road users to the potential presence of pedestrians. Their use should be limited to locations where pedestrians may make unexpected entries into the roadway or where drivers' sight distance is restricted. In San Francisco, placement of pedestrian warning signs has not followed this guidance, leading to an over-proliferation of the signs and a consequent dilution of their effectiveness. The City should review the placement of its pedestrian warning signs and remove them at unwarranted locations, increasing their impact where they are most needed.

Advance Stop and Yield Lines

Stop lines (or limit lines) are solid white lines 12 -24" wide, extending across all approach lanes to indicate where vehicles must stop in compliance with a stop sign or signal. Advance stop lines reduce vehicle encroachment into the crosswalk and improve drivers' view of pedestrians.



Advance stop lines should be considered at stop- or signal-controlled marked crosswalks with limited crosswalk visibility, poor driver compliance, or non-standard geometrics.

Yield lines are optional rows of white triangles placed across approach lanes to indicate the point at which vehicles must yield at locations without a signal or stop sign. Yield lines may be placed in advance of a yield- or uncontrolled marked crosswalk location.

Detailed guidelines for stop and yield lines can be found in the MUTCD, which allows for their use from 4 to 50 feet in advance of crosswalks, depending upon location, roadway configuration, vehicle speeds, and traffic control.

Parking Restrictions at Crosswalks

At crosswalk locations without curb extensions, parking should be restricted at least ten feet in advance of the crosswalk to improve visibility. Up to 20 feet is desirable at signalized locations, however additional measures may need to be taken to prevent illegal parking where demand is high.

Special Intersection Paving

Special intersection paving treatments can break the visual uniformity of asphalt streets, highlight crossings as an extension of the pedestrian realm, and announce key civic or commercial locations. Special intersection paving treatments include integrated colors, textures, and scoring patterns. Special intersection paving treatments may be instituted in the direction of crossings, or across an entire intersection. However, they may be more costly to build and maintain.

Special decorative paving, including colored and/or textured concrete, asphalt or pavers, or any similar treatment does not define a crosswalk. Standard transverse or longitudinal high visibility crosswalk markings are still required.

Special intersection paving treatments may be considered where capital and maintenance budgets allow on:

- Streets important to the city pattern, and commercial streets



▲ Advance yield lines (top) alert drivers to an impending crosswalk; advance stop lines (bottom) require vehicles to stop in advance of a crossing



Pedestrian warning sign



Special crosswalk treatments include high visibility striping on the ramps (apron), a colored paving treatment, and trees in the parking lane



Raised crossing at Octavia and Hayes Streets

- At entries to residential areas where residential streets intersect with higher volume streets
- At key civic locations, such as civic buildings or entries to open spaces
- At mid-block crosswalks

Paving treatments should:

- Use integrated color, texture, and pattern. Potential materials include but are not limited to concrete, stamped colored asphalt, stamped concrete, brick, stone, and unit pavers.
- Use stable, durable, and slip resistant materials per DPW Director's Order 176,112.
- Include edging treatments to visually contrast with the primary material and with the asphalt roadway
- Include crosswalk striping (parallel white lines) on the outer edge of the crossing
- Consider lifespan and long-term maintenance needs of materials in the roadway.

Raised Crosswalks and Intersections

Raised crosswalks bring the level of the roadway to that of the sidewalk, forcing vehicles to slow before passing over the crosswalk and enhancing the crossing by providing a level pedestrian path of travel from curb to curb. Raised crosswalks can be located at intersections or mid block. At intersection locations, the raised area can be extended to include the entire intersection.

Raised crosswalks should be considered at the following locations:

- Where low-volume streets intersect with high-volume streets, such as at alley entrances, neighborhood residential streets, and local access lanes of multi-way boulevards.
- Where a street changes its function or street type. For example, a Commercial Thoroughway may become a

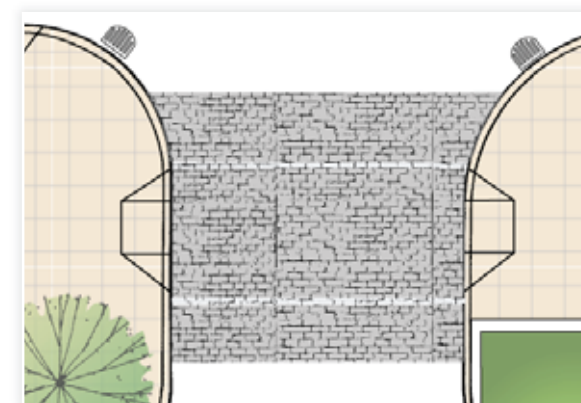

▲ Raised crossings make pedestrian crossing easier and safer by more overtly continuing the sidewalk across an intersection, not only making crossings more visible to drivers, but physically requiring them to slow.

Neighborhood Commercial or a Residential Street as the land uses along it change.

- At key civic locations

Raised crosswalks should not be used on designated transit, SFFD emergency response network streets, or where there are steep grades or sharp curves.

Raised crosswalks should:

- Be flush with the sidewalk in height, and at least the width of the crossing or intersection.
- Be long enough in the direction of travel to allow both front and rear wheels of a vehicle to be on top of the table at the same time - typically 10 feet. Specific lengths should be determined by using the ITE/FHWA document *Traffic Calming: State of the Practice*.¹
- Be instituted in combination with special paving treatments as discussed above, or use the same material as that of adjacent sidewalks.
- Have a concrete apron, where the roadway ramps up or down, to highlight the edges of the crossing.
- Provide detectable warnings where pedestrians will

¹ Available for download at <http://www.ite.org/traffic/tcstate.htm#tcsop>

cross into the vehicle area.

- Provide raised or flush planters or bollards to indicate directionality and a transition to vehicle space.
- Be designed such that the vertical transition does not cause unnecessary jarring or discomfort to vehicle passengers with spinal cord injuries when driven over at the appropriate speed.

Design of raised crosswalks must consider resulting drainage patterns—depending on grade, this may necessitate additional catch basins, trench drains, or other measures.

Pedestrian refuge islands

Crosswalks may also include pedestrian refuge islands to break up the crossing and slow cars. See Section 5.4: Medians and Islands.

Pedestrian Signal Equipment

Pedestrian signal indications should be used at all traffic signals. The international pedestrian symbol signal should be used rather than WALK/DON'T WALK text.

Pedestrian Signal Timing

Pedestrian signals should allow sufficient time for pedestrians to cross the street, including seniors, children, and people with disabilities.

Historically, a standard walking speed of 4.0 feet per second has been used to calculate the minimum pedestrian clearance interval (the flashing red hand plus yellow and any all-red) for pedestrian signals in San Francisco. Upcoming changes to federal standards will likely reduce the walking speed for the pedestrian clearance interval to 3.5 feet per second. In nearly all locations in the City, signals allow pedestrians walking as slow as 2.5 feet per second to cross the entire street if they step off the curb at the beginning of the walk phase.

Walking speed is a function of the age and physical ability of the population. The walking speed used to calculate the pedestrian clearance interval should more closely match that of pedestrians in San Francisco, including the seniors, children, and people

with disabilities. San Francisco is also experimenting with video detection systems to give slower pedestrians additional crossing time. As a next step, San Francisco should conduct studies to determine if slower walking speeds are appropriate and, if so, what those speeds should be.

Exclusive pedestrian phases (e.g. pedestrian ‘scrambles’) should be used where turning vehicles conflict with very high pedestrian volumes and pedestrian crossing distances are short. Leading pedestrian intervals, which give pedestrians a head start before vehicles are given the green, should also be considered on a case-by-case basis at signalized intersections with a high incidence of pedestrian conflicts and right-of-way violations.

In San Francisco, signals on short, fixed time cycles should generally be used rather than actuated signals to allow consistent crossing opportunities. Pedestrian actuation should only be used when pedestrian crossings are intermittent, at locations with relatively long pedestrian clearance time that can result in excessive delay to transit vehicles, and to activate audible pedestrian signals or to provide an extended WALK interval. Since many pedestrians fail to notice pushbutton devices, additional research on passive video and infra-red detection should be conducted.

Timed progression of signals should ensure that sufficient time is allocated per cycle for pedestrian crossings.

Pedestrian countdown signals

Pedestrian countdown signals are designed to enhance the effectiveness of pedestrian signals at clearing the crosswalk before a signal changes direction. Surveys show that most people misinterpret the meaning of the flashing hand of the traditional pedestrian signal. Providing the pedestrian countdown device helps pedestrians better interpret the pedestrian signals. Countdowns also enable pedestrians to stop on a median refuge and wait for the next phase if they find the time left to be too short to finish crossing. Pedestrian countdown signals have been shown to have a 52% reduction in pedestrian injury collisions.¹

Pedestrian countdowns should be provided at all signalized intersections.



Pedestrian countdown signal and accessible pedestrian signal

Pedestrian scrambles allow a dedicated signal phase for pedestrians to cross in any direction at an intersection



¹ Markowitz et al. “Pedestrian Countdown Signals: Experience with an Extensive Pilot Installation,” ITE Journal, January 2006.



In-roadway flashing lights are a relatively new device to help enhance crosswalk visibility



Flashing beacon (at left)

Accessible pedestrian signals

Accessible pedestrian signals (APS) provide information in non-visual format (such as audible tones, verbal messages, and/or vibrating surfaces). The CA MUTCD addresses specific push-button design and placement for APS and contains standards on audible tones, verbal messages and vibro-tactile devices. San Francisco's observations have shown that APS benefits all pedestrians by providing audible and vibro-tactile cues.

APS should be provided at all signalized intersections. It should be prioritized at intersections that are difficult to cross, such as non-standard, skewed, or T-intersections.

Flashing Lights and Beacons

In-roadway flashing lights are intended to call extra attention to pedestrians in crosswalks where signage or other design treatments are deemed insufficient. The flashers can be activated passively with infra-red or microwave detectors, or actively by pedestrian pushbuttons. In San Francisco and elsewhere, in-roadway flashing lights have not performed well due to ongoing maintenance issues. In San Francisco, little or no effect on injury collisions has been discernible (for lack of collisions), but measurable increases in motorists yielding to pedestrians have been found.¹

If their reliability can be improved, then in-pavement flashing crosswalks should be considered at high-conflict uncontrolled crossing locations with posted speeds under 35 mph and significant pedestrian volumes that require extra nighttime visibility or have frequent high-fog visibility restrictions.

Flashing beacons can be used to control traffic at intersections where traffic or physical conditions do not justify a full signal, but crash rates indicate the possibility of a special need, or to provide supplementary warning of a midblock or uncontrolled school crosswalk. They should be considered for use at high-conflict uncontrolled crossing locations with significant pedestrian volumes where visibility is compromised by grades, curves or other conditions.

¹ SF Ped safe final report

The **Transit Priority Flashing Signal** concept benefits pedestrians and transit, and should be explored. See Section 5.5: Transit-Supportive Streetscape Design.

Vehicle Turning Movements at Crosswalks

Right Turn on Red

The California Vehicle Code allows drivers to turn right on red after coming to a complete stop, unless a sign prohibits the movement. Right turn on red (RTOR) prohibitions can be an important tool for increasing pedestrian safety at certain intersections. Under some circumstances, prohibiting RTOR can reduce conflicts and collisions, and it deters motorists from blocking the perpendicular crosswalk while they inch forward to turn. On the other hand, prohibiting RTOR means increased vehicle delay, including delay to transit, with a consequent increase in fuel use and emissions. RTOR prohibition can also lead to more conflicts during right turns on green, since all turning motorists must now wait to make their turn while pedestrians are crossing with the green light.

The CA MUTCD and the Institute of Transportation Engineers suggest considering the prohibition of RTOR under the following circumstances:

- Inadequate sight distance to vehicles approaching from the left (or right, if applicable);
- Geometrics or operational characteristics of the intersection that might result in unexpected conflicts;
- An exclusive pedestrian phase
- An unacceptable number of pedestrian conflicts with right-turn-on-red maneuvers
- Heavy volume of pedestrian crossings
- Request from pedestrians with disabilities using the intersection
- School crossings

- Railroad crossings
- Traffic signals with three or more phases

Beyond those conditions listed above, the City also considers high speeds on cross streets and a verified collision history caused by RTOR maneuvers. As of 2007, signs were posted on one or more approaches of 14% of all signalized intersections citywide (169 out of 1,166).

San Francisco's practice of considering right-turn-on-red prohibition at intersections on a case-by-case basis should be continued, subject to the guidelines listed above.

Multiple turn lanes

Compared to single turn lanes, multiple turn lanes increase potential conflicts between turning vehicles and pedestrians crossing concurrently with the vehicular turning movement. By requiring pedestrians in the crosswalk to divide their attention between vehicles approaching from more than one turn lane, intersections with multiple turn lanes can decrease pedestrian comfort. Safety can be compromised if one turning vehicle obscures the driver's view of pedestrians in the crosswalk from a second, trailing vehicle in an adjacent turn lane. Multiple turn lanes may also compromise bicycle safety.

The presence or absence of multiple turn lanes is not by itself a predictor of an intersection's propensity to generate pedestrian collisions. It is important to consider how removing a multiple turn lane and requiring the same number of vehicles to turn from one lane will affect pedestrian and vehicular safety. However, pedestrian perception of safety and conflict reduction is also an important consideration in intersection design.

Multiple turn lanes should be avoided wherever possible. No new multiple turn lanes with conflicting vehicle/pedestrian movements should be built in San Francisco. Existing multiple turn lanes should be pro-actively eliminated or mitigated.

Feasibility of multiple turn lane removal is contingent upon vehicle level of service, queuing, transit operations, and upstream traffic safety considerations. Even if consideration of these criteria do not point to removal of multiple turn lanes, it may

still be advisable to make lane assignment changes if there is a documented history of relevant collisions involving pedestrians, and other attempted mitigations have proven ineffective.

If removal is not possible, the City should consider potential mitigations for multiple turn lane conditions found to be problematic. Strategies to mitigate problematic multiple turn lane conditions include the following:

- Separate pedestrian and turning movements
- Leading pedestrian intervals
- Permissive-protected signal phasing (pedestrian crossing phase ends before vehicle phase)
- Limited hours of multiple turn lanes
- Parking restrictions
- Signs and enforcement

Crosswalk Closures

San Francisco has a number of closed crosswalks, creating discontinuous pedestrian paths of travel and making walking inconvenient. A primary motivation for closing crosswalks is to safeguard pedestrians in the face of very high traffic volumes or speeds and auto-oriented design, but many times pedestrians ignore crosswalk closures rather than crossing three times to reach a destination that could be reached by one illegal crossing, creating additional safety issues.

New crosswalk closures should not be instituted.

Existing closed crosswalks should be evaluated for opening. This may necessitate additional safety measures such as pedestrian actuation and signal timing changes.





▲ Accessible curb ramps should be provided at all corners, one per each crosswalk end.

▼ A curb ramp should also be provided wherever on-street accessible parking is provided if it is not adjacent to a corner with an accessible curb ramp.



Curb Ramps

Curb ramps provide pedestrian access between the sidewalk and roadway for people using wheelchairs, strollers, walkers, crutches, handcarts, bicycles, and pedestrians who have trouble stepping up and down high curbs.

Curb ramps must be installed at all intersections and mid-block locations where pedestrian crossings exist per ADA guidelines. Curb ramps are required at mid-block locations to access on-street handicapped parking spaces, where provided, and at all new passenger loading zones.

Guidelines

Curb ramps must comply with DPW standard plans. ADA required slopes and dimensions are detailed DPW Curb Ramp Standard Plans CR-1 through CR-6 and summarized in the figure below.

Per standard plans, curb ramps should be installed parallel to the direct path of travel across an intersection. At four-way intersections, two curb ramps should be installed at each corner.

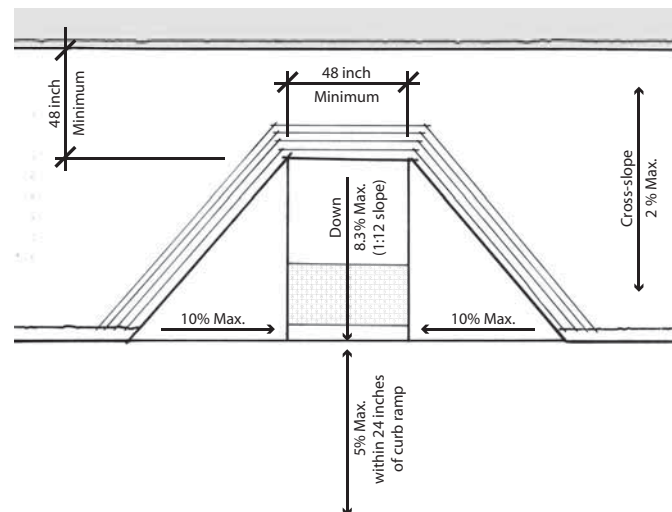

At raised crossings or intersections or other flush transitions between the sidewalk and the roadway, curb ramps are not necessary, but detectable warning strips must be provided.

On new streets, storm drainage inlets should be placed on the uphill side of curb ramps to prevent standing water at curb ramp landings.

Small planting areas can be installed at corners on either side of curb ramps as shown in the diagram below.

A 3 foot deep detectable warning surface must be provided where the ramp, landing, or blended transition connects to a crosswalk.

Curb ramps and crosswalks should remain clear of obstacles. Existing conflicting elements should be moved as opportunities and budgets allow. No new pole, utility or other impediment should be placed in the curb ramp return areas.

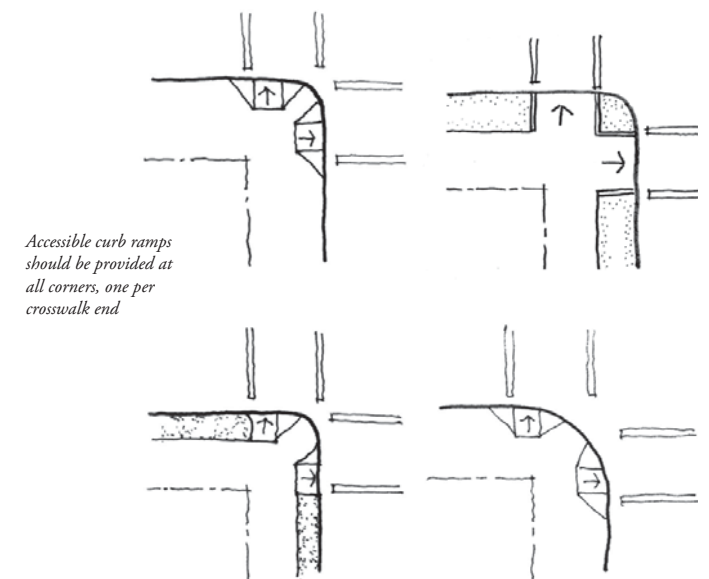

Accessible curb ramps should be provided at all corners, one per crosswalk end.



The length of a corner radius can have a significant effect on the overall operation and safety of an intersection.

5.2 CORNER CURB RADII

The length of a corner curb radius, known also as a curb return radius, has a significant effect on the overall operation and safety of an intersection. Smaller turning radii increase pedestrian safety by shortening crossing distances, increasing pedestrian visibility, and decreasing vehicle turning speed; all of which provide a visual cue to drivers that it is a pedestrian-oriented street and people are more likely to be present.

Curb radii vary with each street type and the transportation context of each street, with considerations based on the guidance provided below.

Guidelines

Curb radii should be designed to maximize pedestrian space and shorten pedestrian crossing distance to the greatest extent feasible; the smallest possible curb radius should be used under most circumstances. In general, curb radii should be as follows:

- 5 feet or less for alleys and where there will be no turns (e.g. intersection of two one-way streets)
- 10 feet for most intersections
- 15 feet for industrial streets

Radii may be larger to accommodate certain design vehicles, but only after measures described below have been exhausted.



Considerations

Curb radii should be designed to accommodate vehicle turn movements per the following considerations:

- The effective turning radius, not the curb return radius, should always be used to determine the ability of vehicles to negotiate a turn.

Effective turning radii for vehicles can be further increased by turning widely to and from additional lanes, per the following guidelines:¹

- Where there are multiple destination lanes in the direction of the turn, vehicles may turn into any destination lane; the furthest left lane on the destination street in the direction of the turn should be used to determine effective turning radius.

- Where there are multiple origin lanes in the direction of the turn, larger vehicles may straddle two lanes in order to start a turn and create a wider effective turning radius; a vehicle slightly angled left and straddling two lanes should be used to determine effective turning radius.
- In some cases, vehicles may turn into opposing traffic lanes on the destination street. On small streets and low-volume streets, curb radii should be determined using the entire width of travel lanes in both directions on the destination street. Where this is a desired treatment on higher-volume streets, advance stop lines (for cross traffic on the destination street) should be used to allow turning vehicles to turn into empty space. Where raised medians are present, vehicles cannot turn into opposing lanes.

¹ This guidance assumes that drivers of larger vehicles are prudent and will not make unreasonable judgments such as turning across the centerline unless the way is clear. This may preclude turns on red and otherwise cause drivers to wait.

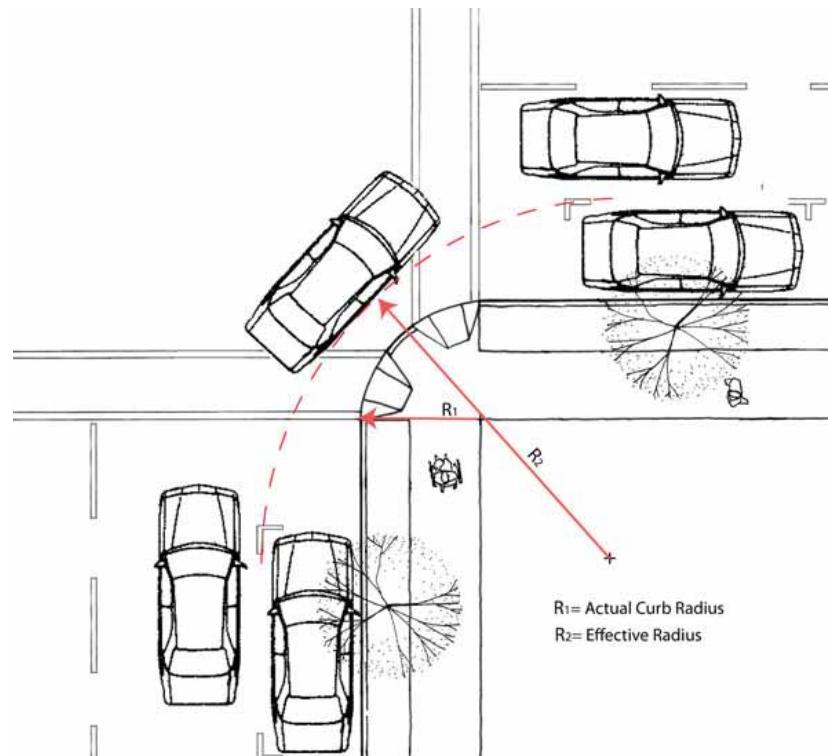

Effective radius: Where a curbside parking and/or bicycle lane is present, the effective radius of the turn is increased, because vehicles will have more space to negotiate the turn.

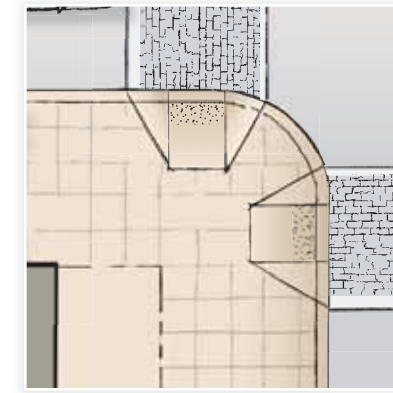

Small curb radii are more pedestrian friendly because they decrease crossing distances and slow vehicles at turns.

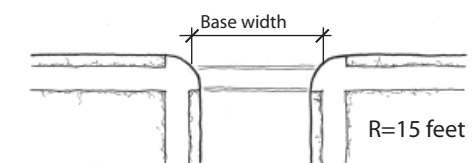
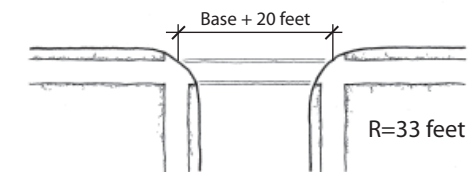
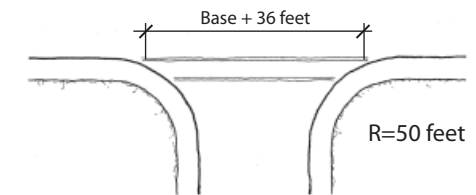

CONTEXT-SENSITIVE INTERSECTION DESIGN

San Francisco has a densely built urban pattern with frequent, narrow streets, high pedestrian volumes, and significant street activity. Many existing streets in San Francisco are narrow, with tight intersections and unusual geometries. Yet pedestrians, cyclists, autos, buses, and delivery trucks successfully negotiate these streets on a daily basis.

Standard street design manuals such as the Caltrans Highway Design Manual (Section 405.8 City Street Returns and Corner Radii) and the AASHTO "Green Book" Policy on Geometric Design of Highways and Streets (Chapter 9, Intersections) do not account for San Francisco's constrained conditions, and generally describe minimum turning radii that are too high.

Curb radii can, in fact, be tighter than many modern guides would allow: older and some neo-traditional cities frequently have radii of 10 to 15 ft without suffering any detrimental effects. ITE's Context Sensitive Solutions in Designing Major Urban Thoroughfares for Walkable Communities provides more appropriate guidance for San Francisco's urban condition. However, even these guidelines may not account for some tighter intersections in San Francisco.

Design vehicles

Curb radii should be designed to accommodate design vehicles per the following guidelines:

- All streets should accommodate turning automobiles; on low-volume streets, or where advance stop lines are provided, the full width of the travel way should be used to determine effective turning radii.
- All streets should accommodate 30' delivery trucks; on low-volume streets, or where advance stop lines are provided, the full width of the travel way should be used to determine effective turning radii. Turns should also accommodate 40' emergency vehicles within the entire roadway.
- Corners with turning buses should accommodate a 40' bus. On low volume local streets, all travel lanes (both directions) should be used to determine the effective turning radius. On Muni 'Rapid' and 'Local' routes, opposing lanes should not be used.
- On designated truck routes ('routes with significant truck traffic' per the Transportation Element of the San Francisco General Plan), a 60' truck should be used as the design vehicle. On arterials and commercial streets, the effect of the turn radii on truck movement should be evaluated, and the potential for trucks to hit fixed objects should be considered (see strategies below). On low-volume streets, the full width of the travel way should be used to determine effective turning radii.

In San Francisco, pre-existing constrained conditions (narrow streets, odd intersection geometries) may make it infeasible to achieve desired turn movements as described below. In these situations it is preferable to provide maximum pedestrian space and instead limit or restrict vehicle movements.

Alternative strategies for intersections with frequent large vehicle turns

Compound radius: A compound radius changes the curb radius over the length of the turn, such that it has a smaller radius at the sides where crosswalks are present, and a larger radius in the center where vehicles are turning. Compound radii effectively shorten crossing distances and make pedestrians visible while

accommodating larger vehicles to turn; however, because they allow more sweeping turns, they do not slow turning vehicles.

Compound radii may be considered where there are high pedestrian volumes, or a desire to make pedestrians visible, but a need for frequent large turning vehicles such as right-turning Muni buses.

At-grade paving treatments: The corner design shown in the figure below can be used to accommodate occasional trucks in very low traffic areas. The area between the large and the small curb returns is at street level, and is textured to discourage high-speed turns but allow low-speed use by longer vehicles. This treatment has limited application, such as industrial streets that have minimal but not inconsequential industrial truck traffic.

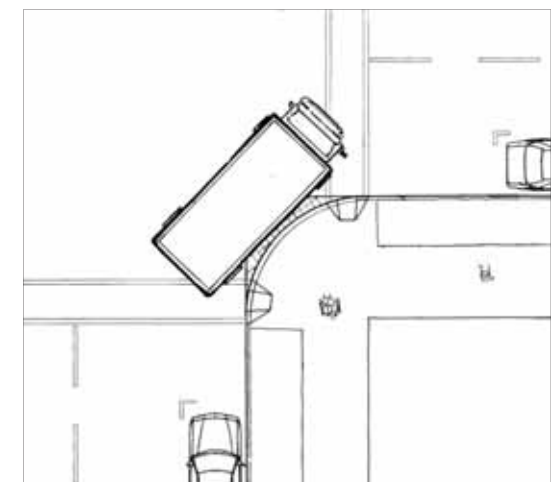
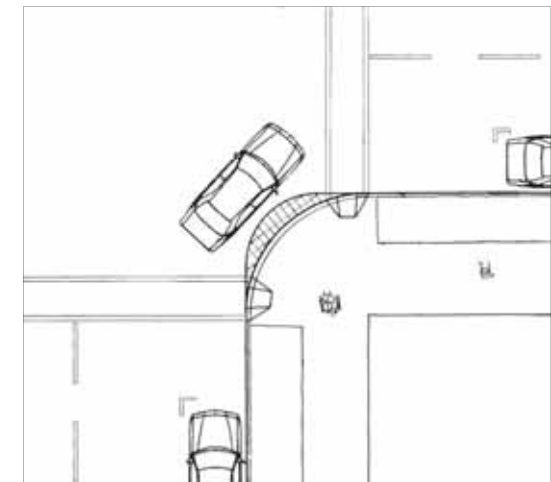



Curb extensions may be lengthened to create public spaces, landscaped areas, or transit waiting areas.

5.3

CURB EXTENSIONS (BULB-OUTS)

Curb extensions (also called bulb-outs) extend the sidewalk into the parking lane to narrow the roadway and provide additional pedestrian space at key locations. Curb extensions can be used at corners and at mid-block locations. Curb extensions are often no wider than the crosswalk, but can be lengthened to create public spaces, landscaped areas, or transit waiting areas. They can also be employed as neckdowns or chokers, traffic calming techniques that reduce vehicle travel lanes.

Curb extensions can have the following benefits:

- Increased pedestrian visibility at intersections through improved sight lines created by placing the waiting area where drivers and pedestrians have better views of one another, and by pulling parked cars back from the crosswalk.
- Decreased pedestrian exposure to vehicles by narrowing the roadway
- Reduced vehicle turn speeds by physically and visually narrowing the roadway
- Increased pedestrian waiting space, which is particularly useful at intersections with high pedestrian volumes
- Additional space for street furnishings, plantings and other amenities
- Reduced illegal parking at corners crosswalks and bus stops
- Facilitated ability to provide two curb ramps per corner

Although curb extensions have many benefits, they may not be appropriate in all circumstances. Use of curb extensions should consider the following:

- They may be more expensive to construct than other measures



- They can reduce flexibility of the roadway in construction routing
- They can reduce future flexibility in making changes to the location of bus zones, roadway lane layout, or crosswalks.
- If built so that left-turning cars block through traffic, they may result in vehicle back-ups

Placement

Curb extensions should be considered on all street types. Specific priority areas for curb extensions include:

- On new streets
- On streets with high pedestrian volumes and/or high traffic volumes and speeds
- On wide streets with long crossing times
- On streets with a history of pedestrian safety concerns
- Where neighborhood streets intersect with busier thoroughways
- On transit priority streets where shortening crossing cycles would improve transit flow

Lower priority areas for curb extensions include streets with lower pedestrian and traffic volumes and lower speeds, such as Neighborhood Residential streets and Alleys. However, they may be considered on these street types as well.

Curb extensions should not be used on streets without a parking lane, or that have a peak period tow-away parking lane.

Curb extensions should be placed at transit stops per Section 5.5. Where curb extensions are provided at transit stops, they should be a full-length transit bulb, and not a standard corner bulb, as it can be difficult for a bus to exit or re-enter traffic around a corner bulb-out.

Guidelines

Curb extensions should be designed to maximize the amount of pedestrian space created, per the following guidelines:

Width and length

Curb extensions should extend the full width of the parking lane, but should generally not extend into travel lanes. Where existing travel lanes have excess width, the curb extension may extend beyond the edge of the parking lane into the travel lane to act as a choker.

On streets with designated bike lanes or bike routes, curb extensions should not encroach on cyclists' space. Where bike lanes use a painted inside edge, the bike lane should be painted continuously as the bike lane passes the curb extension, and the bulb-out should be set back so that the gutter pan does not extend into the bike lane. On lower-speed and volume streets where bikes can travel in mixed flow with vehicles, wider curb extensions may be appropriate, but care should be taken not to force cyclists to merge unexpectedly with faster moving cars at the end of the block

Corner bulb-outs should extend at least 5 feet beyond an extension of the corner property line before beginning to return to the prevailing curb line.



Curb extensions shorten crossings and can act as a choker, narrowing traffic lanes at intersections to calm traffic, improving pedestrian safety at crossings.

(Source: Mike King, Nelson Nygaard)



◀ Beldon Lane is a temporary pedestrian mall with cafe seating at the lunch hour. Curb extensions can be at corners or mid-block locations, and can extend to provide more space to allow seating, planting, and other amenities.



▲ Curb extensions provide usable neighborhood space for community gathering and socializing.

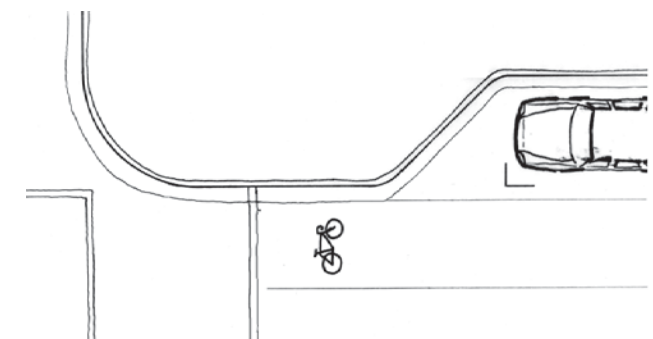

Where bike lanes are present, curb extensions should be set back so that the gutter pan does not extend into the bike lane

STREET SWEEPING AT CURB EXTENSIONS

Currently in San Francisco, interior radii at curb extensions are designed with wide, curving radii so that street cleaning machines can access the entire street. While these are preferable from a maintenance standpoint, they result in inefficient use of space, with less space available for pedestrian use and landscaping, greater parking loss, and a less sharply defined curb extension. Neighborhoods with bulb-outs that don't meet street sweeping requirements, such as Duboce Triangle, have some of the most desirable streets in the city.

The Better Streets Plan recommends as an alternative the use of sharper turn radii, such that curb extensions return to the prevailing curb line to make efficient use of space. Given current maintenance practices, the alternative strategies suggested in the text should only be used on streets without mechanical street cleaning, on areas with a low maintenance burden (for example on North-South residential streets), where maintenance funding or agreements are in place (for example, where CBDs or adjacent merchants or property owners agree to pay for hand street sweeping of corners), or in special cases where the benefit of doing so will outweigh the additional maintenance costs.

However, these recommendations require further discussion and study. Meanwhile, the City should explore maintenance strategies to achieve effective street cleaning at curb extensions with sharp radii, such as expanding the use of maintenance agreements. Specific maintenance recommendations to address this issue will be developed in the next stage of the Better Streets Plan.



Where necessary, driveways can cross curb extensions.

Radii

Curb extensions should follow corner curb radii guidance in Section 5.2.

Curb extensions should return to the prevailing curb line as sharply as possible to maximize useable space and minimize parking loss, per the following guidelines:

Standard return: Existing City standards require an inner/outer curb radius of 20' and 10', sometimes reduced to 15' and 10', enabling street sweeping machinery to sweep the entire curbline.

Non-standard return: Sharper curb returns increase pedestrian space and minimize parking loss while more sharply defining a curb extension. However, they are more difficult and costly to maintain. Where maintenance funding or agreements are in place to account for this, designs may consider the non-standard treatments described below:

- **90 degree return:** Curb extensions may return to the prevailing curb line at a 90 degree angle. This configuration may be used with parallel or perpendicular parking.
- **45 degree return:** Curb extensions may return to the prevailing curb line at an angle. This may be used with either parallel parking (45 degree return) or angled parking (at angle of parking lane).

Standard

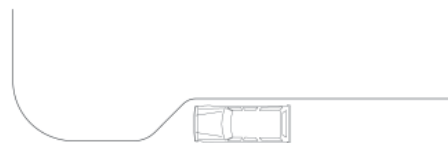

Alternative (angled return - may be parallel or angled parking)



Alternative (90 degree return - may be parallel or perpendicular parking)

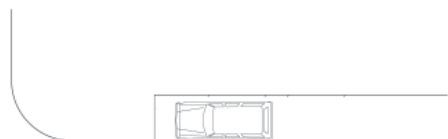

Other design features

Bollards, planters, or other fixed objects should be used where necessary to protect pedestrians and prevent vehicles from driving onto the sidewalk. These elements may be directly at the back edge of the curb.

Curb extensions should be designed to hold the 100-year storm within curb width. Stormwater features can help to offset reduced capacity from curb extensions. Individual analysis should be conducted for each project.

Curb extensions should either relocate the corner catch basin to the outer edge of the extension, or provide a covered channel (trench drain) to convey stormwater to the existing catch basin (see side bar, following page). The channel must be covered with an ADA-compliant cover.

Driveways may cross curb extensions.

Extended Bulb-Outs

Longer curb extensions should be considered to create space for seating, landscaping, stormwater features, and other amenities. Extended bulb-outs should use special paving or an edging treatment to distinguish the space as a plaza space separate from the through travel area.

Street furnishings and other above-grade objects should be located on curb extensions outside of crossing areas to increase space for pedestrian through travel on the sidewalk.

TEMPORARY CURB EXTENSIONS

In some cases, the City may want to consider temporary curb extensions. These can be created by delineating the edge of a curb extension form with bollards, striping, and other elements that will demark and protect the extended sidewalk corner without requiring construction to bring the level of the curb extension up to the sidewalk. This should be considered a temporary treatment until funding and time allow construction of a standard raised curb extension.

MAKING SIDEWALK WIDENINGS AND BULB-OUTS MORE COST-EFFECTIVE

Corner bulb-outs and sidewalk widenings are among the most effective tools to enhance pedestrian safety and quality. They are essential components of a truly successful pedestrian environment.

However, they are significantly expensive to construct, particularly when compared to other potential strategies, which often prohibits their inclusion in pedestrian projects with limited budgets. The high cost of building bulb-outs and widenings comes from various factors, including:

- Demolition and reconstruction of curbs
- Re-grading of the roadway
- Curb ramp construction
- Re-alignment of utilities lines and poles
- More costly when re-paving
- Catch basin relocation
- Fire hydrant relocation (where hydrants are present)

Some strategies may be considered to reduce costs:

1. Allowing utility lines and vaults to remain in place when constructing curb extensions and widenings may also sig-

nificantly reduce construction costs but may increase long-term maintenance costs. Concrete sidewalks may also be less costly to excavate and replace than asphalt streets with concrete sub-base when accessing utilities.

2. Capital costs may be reduced in some cases through the use of trench drains (channels covered with metal grating). Trench drains may eliminate the need to relocate catch basins or re-grade streets for drainage (for example, by allowing water to flow through existing gutters at a mid-block bulb-out). However, they also require additional regular maintenance to clean out channels, particularly on high-use and commercial streets.
3. Fire hydrant relocation can be prohibitively expensive (\$40,000-\$70,000) when constructing sidewalk bulb-outs or widenings depending on the location of existing utility lines, often resulting in a decision to not construct a particular curb extension. Current Fire Department standards require hydrants to be between 24 and 27 inches from the curb line. When curb lines are moved, hydrants that are present must be shifted as well. Allowing hydrants

to remain in place would result in significant cost savings for constructing bulb-outs and widenings. The bulb-outs would also keep the area clear of illegally parked cars, which improves access to the fire hydrants. Instead of moving hydrants, in-street reflectors, painted curbs, and other technologies may be used to make existing hydrants easy to locate.

All of these recommendations require additional discussion and study.

For 1 and 2, the City should conduct life-cycle cost analyses, taking into account the benefits of curb extensions, to determine appropriate usage. At present, where trench drains are used at high impact locations, there should be a funding plan for maintenance or maintenance agreement in place.

For #3, additional discussions with the Fire Department are necessary. The City should seek a solution that addresses the need to easily and quickly locate hydrants while enabling the cost-effective construction of curb extensions with significant pedestrian safety benefits.



To decrease the potential cost of curb extension construction, trench drains can be used to allow pre-existing catch basin locations to be maintained. It is important to give proper proportions to trench drains. The smaller trench drain (center) is well proportioned and attractive, while the wide trench drain (right) is visually too dominant.

BEST PRACTICE: NE SISKIYOU GREEN STREET

PORTLAND, OREGON

This project, completed in 2003, is believed to be first in the U.S. to deliberately use landscaped curb extensions, or extensions, to manage stormwater runoff. A portion of the parking zone was converted into two landscaped curb extensions designed to capture, slow, cleanse and allow infiltration of street stormwater runoff. The curb extensions provide ancillary benefits such as traffic calming and neighborhood greening.



How does the project work?

Stormwater flows downhill along the street curb until it reaches the curb extensions, which are seven feet wide and 50 feet long. The water is channeled into the curb extensions through 18-inch wide cuts in the curb. Inside the landscaped curb extensions, the water is retained up to a depth of seven inches by a series of checkdams.

Depending on the runoff volume, water will cascade from one "cell" to another until plants and soil absorb the runoff—at a rate of three inches per hour—or until the curb extensions reach their storage capacity. If capacity is reached, water exits the landscape area through a curb cut at the other end of the curb extensions back into the street and flows into the street inlets. The landscaped curb extensions are able to manage nearly all the annual stormwater runoff from approximately 10,000 square feet of NE Siskiyou Street and neighborhood driveways, estimated at 225,000 gallons.



Top and Bottom: Curb extensions can create a variety of types of usable and attractive spaces for pedestrians at mid-block locations.



Mid-block Bulb-Outs

Mid-block bulb-outs should be considered on all street types to provide additional sidewalk space for landscaping, seating, stormwater treatment, and amenities, and improve safety at mid-block crossings by shortening crossing distances and enhancing visibility for pedestrians waiting to cross the street. Mid-block bulb-outs should consider the following guidelines:

- Mid-block curb extensions should include bollards, landscaping, or other buffers between pedestrians and passing vehicles, with a height, width, and general design that does not impede a driver's view of pedestrians.
- Mid-block curb extensions should use special paving or an edging treatment to distinguish the space as a plaza space separate from the through travel area
- Street furnishings and other above-grade objects should be located on curb extensions where space allows to increase space for pedestrian through travel on the sidewalk.
- Mid-block curb extensions should be used at designated mid-block crossings. Mid-block crosswalks should be provided per Section 5.1, Crosswalks

The City should explore the use of curb extensions should be added in front of fire hydrants so that the hydrant is not blocked by illegally parked vehicles. This arrangement shortens the “no parking” zone around fire hydrants and typically adds one parking space. However, this would require a change to current City standards. See discussion, previous page.



Top and Bottom: Mid-block bulb-outs can provide space for landscaping, cafe seating, or pedestrian furnishings.



Medians and islands can calm traffic and provide safe pedestrian refuge, while incorporating space for amenities, landscaping and stormwater management

5.4

MEDIANS AND ISLANDS

A median is the portion of the roadway separating opposing directions of the traveled way, or local lanes from through travel lanes. Medians may be depressed, raised, or flush with the road surface. Medians are generally linear and continuous through a block. An island is defined as an area between traffic lanes used for control of traffic movements. Within an intersection, a median is considered an island.¹

Raised medians and islands provide space to locate pedestrian safety features and traffic control devices, amenities, landscaping and stormwater management. They can provide a traffic calming and aesthetic benefit, but the addition of medians alone in some situations can also cause an increase in vehicle speeds by reducing friction between opposing directions.

From a traditional traffic engineering perspective, the principal functions of medians are to:

- separate opposing traffic
- provide a recovery area for out-of-control vehicles
- provide an emergency stopping area
- provide space for speed changes and storage for left- and u-turns
- minimize headlight glare
- restrict through travel on streets with two-way left turn lanes or where cross streets intersect with more significant throughways

¹ AASHTO Green Book



Raised medians and islands may also play the following very important roles:

- provide space for a pedestrian refuge on wide streets where those on foot cannot cross the entire street in one phase
- reduce excessive pavement areas, and provide open green space
- provide space for transit stops
- separate through traffic from local traffic on Multi-way Boulevards
- create space for a distinctive design treatment

Where no median is present, raised islands can be used as traffic calming features to briefly narrow the traveled way, either in mid-block locations, or to create gateways at entrances to residential streets. Islands may also be found at corners.

Guidelines

At crossings, the end of medians should be flush with the edge of the crosswalk and should not be significantly rounded. A thumbnail should be provided in medians used as pedestrian refuge islands.

Medians should be combined with parking lane planters, chicanes, curb extensions or other traffic calming measures where it is desirable to further moderate traffic speed.

Medians and islands more than 3 feet wide, including curbs, should be landscaped and used for stormwater management wherever possible. Plantings should use drought-tolerant, low maintenance species. When street trees are desired, a median should be 5 feet wide, including curbs, to provide sufficient space for healthy root growth. See Section 6.1: Urban Forest.

Landscaped medians should be configured so that maintenance personnel do not have to work in traffic lanes, using discontinuous plantings, edging, or striped areas adjacent to medians. In new streets and for retrofits where budget allows, medians should be built to the maximum width possible, rather than providing a striped area outside the median.

Design and landscaping of medians should emphasize continuity on throughways and ceremonial streets. Landscaping, lighting and street furnishings should maintain a similar look and feel even as the corridor varies in land use, scale and intensity.

Islands should not interfere with driveway access, unless that is the purpose of the installation (i.e. access management).

Pedestrian Refuge Islands

Pedestrian refuge islands are protected areas where people may safely pause or wait while crossing a street. Pedestrian refuge islands are particularly helpful as resting areas for seniors, persons with disabilities, children and others who may be less able to cross the street in one stage. At signalized intersections, they al-

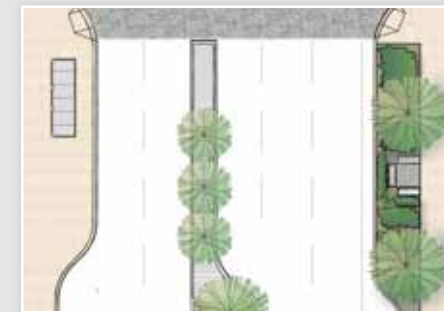

Medians provide space for trees and planting, visually break down the scale of the right of way, and create space for pedestrian refuges. (Source: Mike King)



Left: Landscaped medians provide visual continuity to a corridor.

Right: Median islands can also have significant aesthetic impact on a street and designate entrances to residential streets.

STORMWATER MANAGEMENT IN MEDIANS

Landscaped medians reduce impervious space in the roadway, allowing stormwater infiltration or retention in the exposed soil. Medians can also be designed to retain, cleanse, and infiltrate stormwater runoff from the roadway, replenishing groundwater and decreasing the peak flow burden on stormwater infrastructure. Where stormwater management is intended in the median, the street should be graded to drain toward the median. For more information on stormwater management, see Section 6.2.

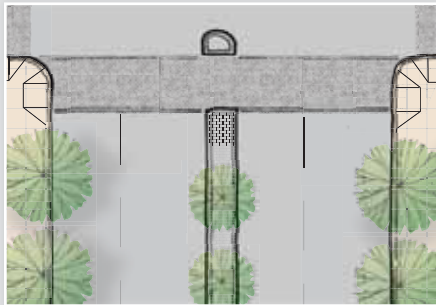

Pedestrian refuges provide space for pedestrians to wait on longer crossings and can include a variety of amenities.



CHOOSING MEDIAN REFUGE ISLANDS VS CURB EXTENSIONS

Pedestrian refuge islands and curb extensions both improve comfort and safety for pedestrians crossing through intersections or mid-block crossings. Curb extensions minimize the distance needed to cross wide streets and facilitate crossing in one stage, while pedestrian refuge islands offer a comfortable resting place in between crossing stages.

Under the following conditions, median refuge islands may be preferable to curb extensions, or it may be appropriate to use median refuge islands in addition to curb extensions:

- two-way left-turn lanes
- excessively wide travel lanes or turn lanes
- 4 lanes or more where it is not always possible to cross in one stage
- a ceremonial purpose, where medians provide an important design function
- an existing median, where pedestrian refuges may be less costly to build than curb extensions

low slow moving pedestrians to cross in two phases. At unsignalized locations, they simplify the act of finding a gap in traffic to cross since vehicles from only one direction must be reckoned with at a time.

Raised pedestrian refuge islands can be provided in painted center medians, side access lane medians, transit boarding islands, and corner islands.

Placement

Pedestrian refuge islands should be considered under the following conditions:

- streets with high pedestrian activity
- where crossing distances are long (60 feet or greater)
- near and within neighborhood retail areas, near civic uses, near schools and senior facilities
- locations with many transfers between transit lines
- unsignalized intersections with large numbers of pedestrians

Dimensions

On streets with medians less than 7 feet wide, signals should be timed so that pedestrians can cross in one signal phase and detectable warning strips are not required.

On medians between 7 and 12 feet wide, the pathway and waiting area should be at street grade, with 2' deep detectable warning strips at each edge.¹

On medians 12 feet wide or greater, pedestrian refuge islands should be raised to provide more visibility for waiting pedestrians. Raised islands should include two curb ramps with detectable warning strips and a 4 foot wide waiting area.

See figure below.

¹ Two feet deep detectable warning strips should be used within medians and islands, differentiated from 3' at the roadway edges, to indicate that the pedestrian is still within the middle of the roadway

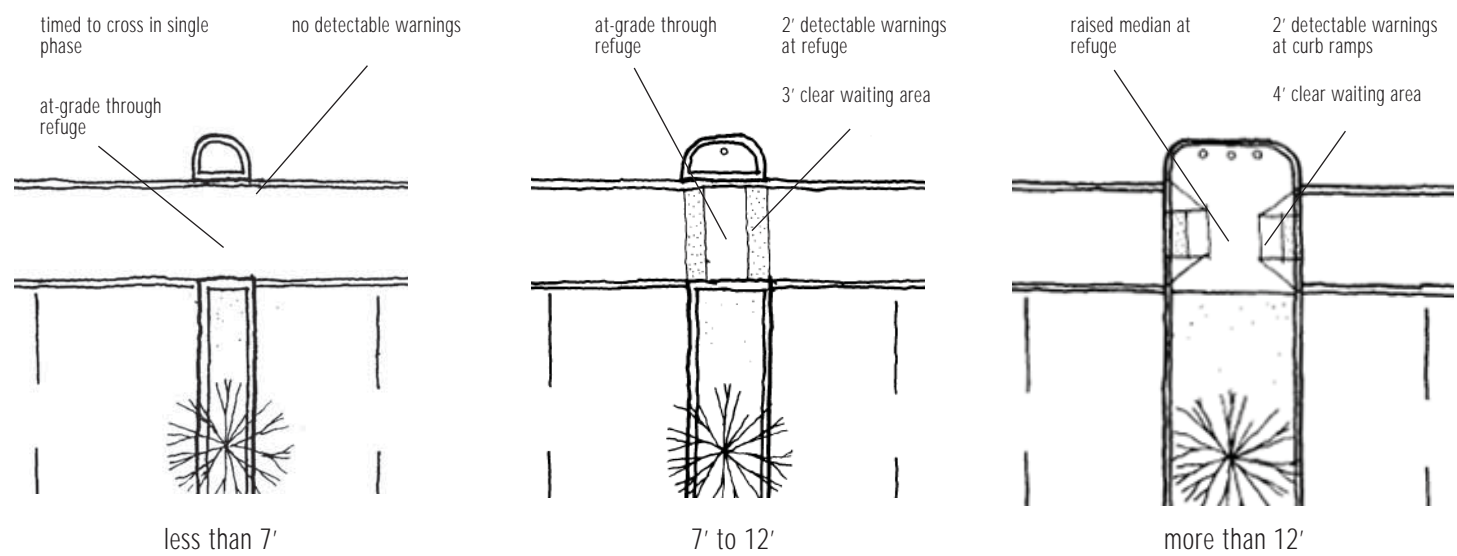

Median design at various widths

Safety and Design Elements

In order to protect waiting pedestrians, the following elements should be used in pedestrian refuge islands:

- Raised thumbnails should be provided on the intersection side of refuge islands. Ideally, thumbnails should be located outside of the crosswalk edge.
- To accommodate turning radii for large vehicles, the thumbnail may need to be within the crosswalk, or have a mountable outside edge. Mountable thumbnails should be built so that pedestrians are discouraged from standing on the thumbnail itself (for example, by using cobbles or another uneven paving material).
- A bollard, landscaped feature, or sign should be provided on the thumbnail, unless it is a mountable thumbnail. These features should be 2 to 4 feet tall. Taller elements such as light fixtures or sign poles may be appropriate if they are thin enough to not obscure drivers' view of pedestrians.
- Pedestrian refuge islands should use different paving (concrete or other) in order to distinguish them from the roadway. See Section 6.4: Paving.
- On wider medians, a seatwall may be provided.



(Source: Mike King)

Corner Islands

Where the pavement area within an intersection becomes excessively large as a result of efforts to accommodate turning movements of large vehicles or due to streets coming together at unusual angles, adding corner islands can help control traffic and break up the crossing for pedestrians.

Adding corner islands creates what is generally referred to as a slip lane, which separates right turning vehicles from through traffic. Slip lanes can be stop- or signal-controlled, but are often yield-controlled.

Slip turn lanes and the very large corner radii that come with them can pose a hazard to pedestrians for a number of reasons:

- drivers tend to concentrate on merging with oncoming traffic and may not see pedestrians entering the crosswalk
- in high-traffic areas, inadequate gaps in uncontrolled right-turning traffic may exist, making crossing a slip turn lane difficult for pedestrians
- the non-standard corner geometry introduced by slip lanes is extremely difficult for people with visual impairments to negotiate

OFFSET OR 'CORRAL' CROSSINGS

Offset crosswalks are treatments in which the crosswalk is split by a median and is offset on either side of the median. This design forces pedestrians to turn in the median and face oncoming traffic before turning again to cross the second half of the roadway, which may improve safety, especially where there is no signal control at mid-block and T-intersection locations.

While offset crossings provide safety benefits, they may inconvenience or delay pedestrians. Wherever feasible, pedestrians should be given sufficient time to cross the entire roadway in one phase. However, two-phase crossings may occasionally be unavoidable from a vehicle or transit operations standpoint, and, especially on transit corridors or where foot traffic is light, they can minimize person delay.

One potential issue with staggered crosswalks is that, unless they provide tactile cues for visually impaired pedestrians to re-orient themselves before crossing the second half of the roadway, pedestrians navigating with a cane may be misdirected. Offset crosswalks should be built so that each side of the median pass through features a curb running parallel to the crosswalk, forming a "Z".

In order to discourage shortcutting and encourage pedestrians to follow the intended path, some staggered crosswalks include a railing to contain pedestrians and direct them along the desired route. This treatment is often referred to as a corral-crossing since the railing can produce a corral-like effect, and should be avoided.



Care should be taken to design a pleasant walking environment that does not make pedestrians feel like barnyard animals. A low seatwall or landscaping may provide an attractive alterna-

Offset crossings should minimize inconvenience to pedestrians. The photo at bottom would benefit from a feature to redirect people with visual impairments to the direction of the crosswalk.

Source (bottom image): http://www.contextsensitivesolutions.org/content/case_studies/mid-block-crosswalks-school-zone-olympia-wa/



A center median island, right turn channel (corner) island, and side access lane median pedestrian refuge. (Source: Mike King)

Slip lanes and corner islands should be avoided, and removed to create additional pedestrian space and a safer crossing, wherever possible.

Where the large turning radius provided by a slip lane proves unnecessary, removing the slip lane and squaring up the corner will reduce both speeds of turning vehicles and pedestrian exposure. Reclaimed space from slip lane removal can be made into an attractive area for pedestrians through the use of site furnishings and small-scale plantings.

At intersections with very high right turning volumes or which must accommodate very large vehicles, slip lanes may be unavoidable. Where it is not possible to avoid or remove slip lanes, their design should be mitigated, per the following guidelines:

- Raised islands should be provided to provide a pedestrian refuge
- Uncontrolled slip turn lanes, especially those that turn into a dedicated exit lane (free right turn slip lanes), are discouraged where pedestrians are present

- For maximum pedestrian benefit, slip lanes should be designed with a maximum 30-35 foot turning radius; however, they should follow the guidance in Section 5.2.
- They should incorporate additional measures to enhance pedestrian safety. Signaling the right-turn movement creates gaps in vehicle traffic for pedestrians and may be the safest alternative. Passive crossing treatments, such as warning signage, or a raised crosswalk connecting the sidewalk with a refuge island, should also be considered. Finally, slip turn design may employ a variable (compound) radius to slow vehicles and improve drivers' visibility, as shown in the middle diagram below (See Section 5.2: Corner Curb Radii).

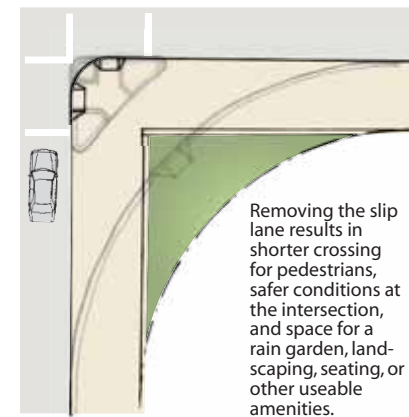
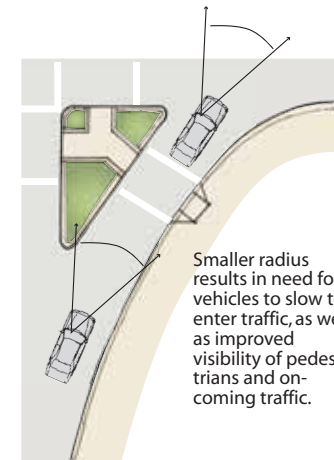
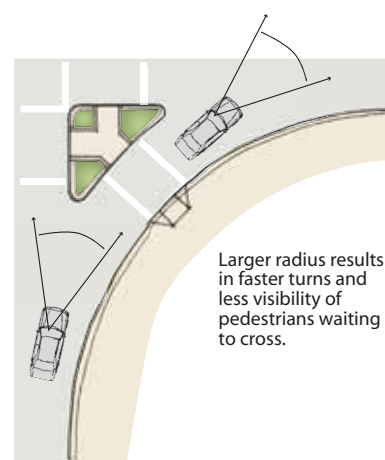

A vintage trolley is the central focus, positioned on a city street. The trolley is light-colored with large windows and a sign that reads "FISHERMAN'S WHARF". The number "18-93" is visible on the front. Several people are standing on the sidewalk next to the trolley, some looking towards it. The background shows a city street with buildings and trees. The overall scene is in black and white, with a semi-transparent text overlay on the right side.

Transit supportive streetscape design includes safe, comfortable transit waiting areas, convenient routes to transit, and design to enhance pedestrian and transit circulation

5.5

TRANSIT-SUPPORTIVE STREETScape DESIGN

Transit stops are critical elements of the public realm that enhance the experience of boarding a bus or light rail train. Successful transit stops are well connected to the local network of sidewalks and bicycle facilities in order to allow a convenient connection to residential neighborhoods, work places and shopping or civic destinations.

Streetscapes can be designed to be more or less supportive of transit operations. In many cases, streetscape designs that benefit pedestrians can also be helpful to transit.

Guidelines

Placement

Sidewalk transit stops should be located in a curb extension wherever possible. Transit stops should be located in median islands where transit uses center lanes.

Transit stops should be located in places that are active and visible to maximize personal security of waiting transit riders.

Transit stops should not be located at driveways; new driveways should be discouraged at transit stops.



Layout

Good layout of a transit stop offers transit patrons visual cues on where to sit or stand and wait. The transit area should be clearly defined using the following treatments:

- Curb extensions (where appropriate—see below), particularly where sidewalks do not provide adequate space for both a transit shelter and sufficient clear pedestrian width.
- Special paving treatments
- A line of trees or containerized planters, where space allows

Important considerations for the layout of transit stops include the following:

- Site furnishings should be consolidated as much as possible
- Bus stop signs should be placed near the front of the stop, where waiting customers should stand to board the bus
- Lighting should be located near the front of the stop and at the transit shelter
- At larger and more important stops, multiple pedestrian-scale lighting fixtures should be included to provide ample lighting in all areas where pedestrians may wait
- Stops should be integrated with adjoining activity centers wherever possible

Transit stops must include the following accessibility features:

- Sidewalk loading areas require a clear, solid concrete loading platform 5 feet wide and 8 feet deep perpendicular to the curb to allow a transit vehicle to extend its ramp for people with mobility impairments. This pad must have a maximum 2% slope perpendicular to the curb and a cross slope equivalent to that of the roadway parallel to the curb. It should also be readily accessible from the adjacent transit shelter and sidewalk.

- A 30-inch by 48-inch clear floor wheelchair space must be provided completely within the transit shelter. This space must be readily accessible from the sidewalk and the loading pad as described above.

Amenities

Transit stops and their surrounding area deserve a higher than average level of streetscape amenities. Elements that should be considered include the following:

- A flag sign with pedestrian-scale wayfinding signage and route information
- Pedestrian-scale lighting (see Section 6.3)
- Seating (inside and/or outside of shelters)
- ‘Leaning’ bars where space for benches is limited or waits are short
- Real-time schedule information where available, route maps and, where appropriate, an orientation map to guide people to surrounding destinations
- Trash and recycling receptacles
- Convenient and secure bicycle racks
- Newspaper racks
- Ticket vending machines (where applicable)
- Street trees and other landscaping (see discussion below)

Transit shelters should be included wherever existing sidewalk space allows or where a curb extension can be added to provide sufficient space, and demand warrants.

Transit shelters should not be provided where existing sidewalk width is insufficient to accommodate a shelter and the minimum required clear path of travel around the shelter.

Shelters should be located in the furnishings zone wherever possible. They should allow 4 feet of space between the edge of the curb and the front edge of the shelter, or another accessible path to the shelter should be provided. Alternately, shelters can be



Top: Many existing transit stops are space constrained and provide limited circulation

Bottom: Transit stops should include sidewalk treatment, better circulation, a clear flag sign, pedestrian lighting, trees, and amenities to make a safe and pleasant waiting experience.





Curb extensions provide more space for amenities, passenger waiting, and sidewalk through travel at transit stops.

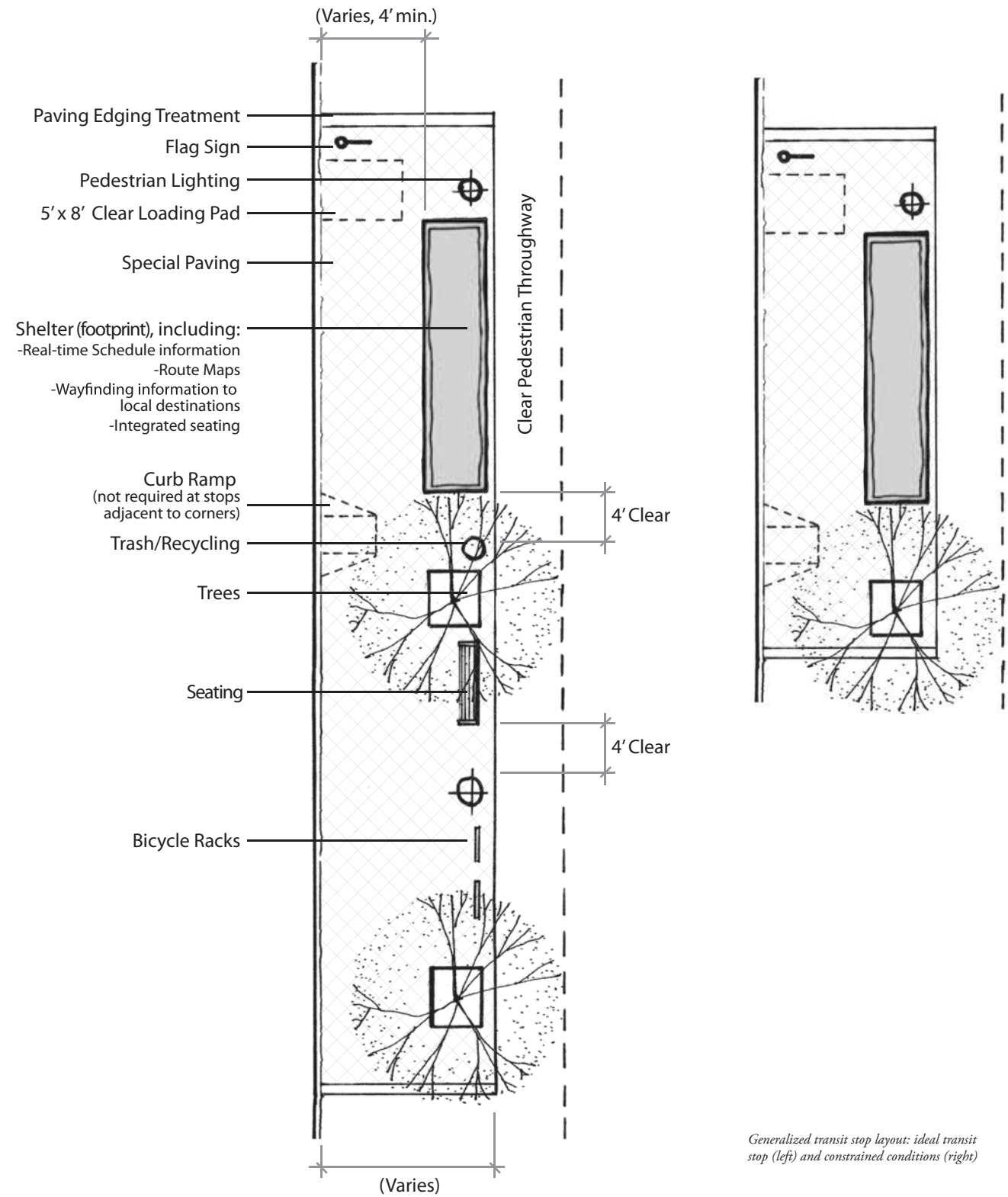

Generalized transit stop layout: ideal transit stop (left) and constrained conditions (right)

placed in the frontage zone so long as they don't block building entrances, but should allow 5 feet between the edge of the curb and open front of the shelter.

Landscaping

Trees and planters should be used to define the transit stop space but should not interfere with transit operations or pedestrian travel. See Section 6.1: Urban Forest for the correct placement of trees and planters within transit stops.

Trees should continue the prevailing pattern of street trees along a corridor wherever possible. See Section 6.1: Urban Forest.

Priority Transit Corridors

In addition to the guidelines above, special considerations should be made for transit stops on designated Rapid Network corridors, on Transit Preferential Streets, at major transfer stations, and stations frequented by people not familiar with the local transit system.

Rapid Network stops should have a special identity and effectively be “branded” so that they are clearly unique from standard transit stops. Rapid Network stops should include special

signage, a higher level of design treatment, and greater amenities including payment systems at stations.

For important transfer stops, where many passengers regularly change from one transit line or system to another, special considerations should be made in the design of stops to facilitate quick, safe and comfortable transfers. Clear wayfinding signs, visual cues to link facilities, and a clear direct path of travel can aid transferring passengers. Linking stops with a consistent paving treatment unique from surrounding paving should be considered.

Where transferring passengers must cross streets, high visibility crossings, curb extensions, and other measures to improve pedestrian safety at crossings should be considered.

Transit Bulb-Outs (Bus Bulbs)

Bus bulbs are curb extensions that serve a transit stop. Bus bulbs can improve both transit performance and pedestrian conditions.

Bus bulbs assist with proper alignment of transit vehicles and improve transit performance because transit vehicles do not have



Bus bulb-out



Curb extensions improve transit performance by allowing transit vehicles to load from the travel lane, removing the need to wait for a gap to re-enter traffic.

BUS BULB AND BOARDING ISLAND LENGTHS FOR CURRENT MUNI VEHICLES

- LRT vehicles (two-car train): 155'
- 1 Standard 40' bus: 35' near side; 45' far side
- 1 articulated 60' bus: 55' near side; 65' far side
- 2 standard buses: 80' near side; 90' far side
- 2 articulated buses: 120' near side; 130' far side

These requirements may change as Muni vehicle technologies change.

to exit and re-enter the flow of traffic at each stop. They may also improve pedestrian conditions by providing extra space for waiting and passing pedestrians and locating the transit shelter out of the way of pedestrian flow.

Placement

Bus bulbs should be considered on all streets with side-running transit and a parking lane, except:

- Where there is a peak period tow-away parking lane
- Where there is a desire to have a queue jumping lane for buses
- At near side stops with heavy right turn movements

Bus bulbs should be prioritized:

- On Rapid Network lines, and selectively on local and other lines at critically impacted locations
- Where existing sidewalk width is too narrow to accommodate a transit shelter, or where pedestrian through travel is constrained
- Where transit performance is slowed significantly due to the time delays caused by reentering traffic flow, and a bus bulb will mitigate this problem.

At signalized intersections, bus bulbs should often be located at far-side bus stops to facilitate bus operations, transit signal priority, and pedestrian movement. This also enables the crossing to be located behind the bus, which is preferable for pedestrian safety.

Guidelines

Transit curb extensions should follow the curb dimension guidelines specified in Section 6.3: Curb Extensions.

Curb extensions should be long enough to accommodate all doors of transit vehicles that will load and unload at the curb extensions plus an additional 5 feet for imprecise stops. Where there is frequent service, bus bulbs and boarding islands should be long enough to accommodate two vehicles, with a 5' space in between.

Transit Boarding Islands

Transit boarding islands are waiting areas located on a median in the roadway rather than on the sidewalk. Transit boarding islands can significantly improve transit vehicle performance and safety because vehicles can run in the center lane, and do not have to exit and re-enter the flow of traffic at each stop. On multi-way boulevards with transit running in center lanes, transit stops should be placed on side medians.

Transit boarding islands can also provide more space and amenities at transit stops with the heaviest pedestrian traffic by providing extra waiting space for transit riders outside of the primary sidewalk.

Guidelines

Transit islands should be raised above the street level and include street lighting to illuminate the waiting area. They may also include the following:

- Special paving
- Grass or low plantings at the oncoming traffic end of transit boarding islands beyond the pedestrian waiting area

Amenities such as shelters, seating, signage poles and ticket vending machines should have as small a profile as possible and be arranged along the back edge of the median.

Transit shelters should be transparent and should leave 4 feet of clearance in front, which may require removing the sidewalls of the shelter to enable people to pass in front of the shelter.

Dimensions

Transit boarding islands should be at least as long as the distance between the front of the vehicle and the rear-most door plus 5 feet. At stops where two or more vehicles are expected to stop simultaneously, the island should be large enough to accommodate both with 5 feet of space between the two stopped vehicles.

Transit boarding islands must include a standard 5-foot wide by 8-foot long clear loading pad for buses to extend their ramp or

lift for persons with disabilities to board, or other accessible facility, such as a raised platform with ramp. The median should be designed so that the door or doors of the bus or streetcar used for accessible boarding aligns with the boarding area.

Pedestrian Access

Transit boarding islands should be served by the primary pedestrian system and have a crosswalk with curb ramp access at one end, at a minimum, connecting to the sidewalks of the street. They may serve as a pedestrian refuge for street crossings. The following treatments should be considered to enhance the design of transit stops and signal that they are a location where high numbers of pedestrians are likely to be present:

- Provide a raised or high visibility crossing with special paving
- Pave the side lane in concrete or other special paving

Additional Transit Operations Considerations

Bulb-outs on side-street crossings should be used on transit routes to enhance pedestrian safety and transit operations. At signalized intersections, bulb-outs can extend green time available for transit on the major street by reducing pedestrian crossing times.

At transit stops, bulb-outs should be full-length bus bulbs, and not a standard corner bulb, as it can be difficult for a bus to exit or re-enter traffic around a corner bulb-out.

Where buses and signals are equipped with transit priority technology, development of the Transit Priority Flashing Signal could eventually offer an optimal balance between pedestrian and transit priority. The Transit Priority Flashing Signal concept is being developed in conjunction with the Transit Effectiveness Project to enable the pedestrian priority of a stop sign at intersections with a “Transit Preferential Street” where non-transit vehicular traffic volumes do not warrant a signal. The flashing signal would be interrupted only when a transit vehicle approaches and triggers a green phase and a red phase to stop cross traffic (vehicles and pedestrians). The intent is to favor pedestrian movement at all times except when transit vehicles pass through,

balancing San Francisco’s “Transit First” policy with the pedestrian-friendly feature of a stop sign.

Traffic calming devices on bus routes should be compatible with bus operations (see Section 5.7: Traffic Calming). In particular, strategies involving vertical and horizontal deflection that could affect transit on-time performance and rider comfort should not be used, particularly on Rapid and Local routes. Effective corner radii should balance the necessity to accommodate transit vehicles with the need for safe pedestrian crossing conditions (see Section 5.2: Corner curb radii).

Where schedules are not coordinated, patrons transferring between lines are often hurried and heedless of their surroundings. Timed transfers at key points on major lines with less frequent headways or in off-peak hours should be considered as a strategy to allay fears of missed connections that lead to dangerous behavior. Likewise, consideration should be given to facilitating increased communication between drivers of connecting lines in order to discourage unsafe crossing by passengers hurrying to catch a connecting bus.

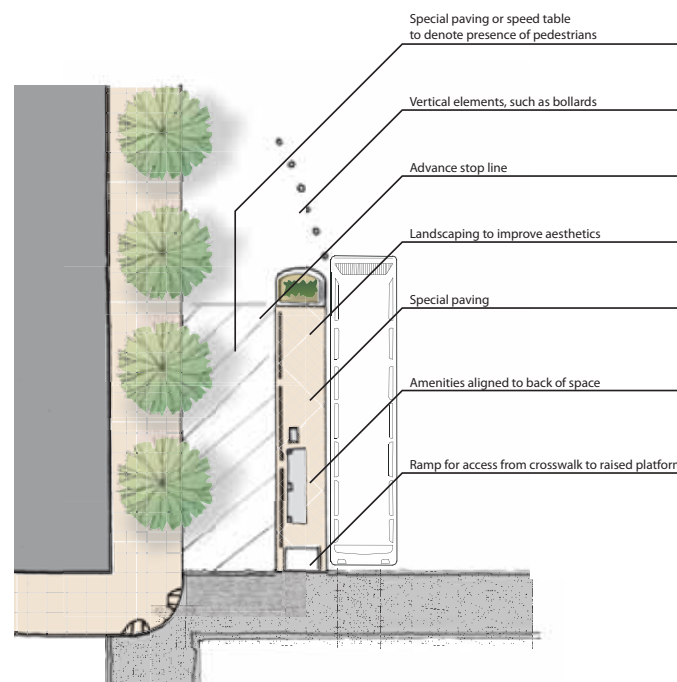

Transit boarding island



Transit boarding islands are necessary wherever transit runs in lanes other than the right-most travel lane. (Source: Mike King)



Source: Nelson\Nygaard



Source: Nelson\Nygaard



Parking lanes may be configured to provide a variety of streetscape and pedestrian amenities, such as landscaping, bicycle parking and flexible use.

5.6

PARKING LANE TREATMENTS

In addition to supplying parking for businesses and homes, on-street parking provides an important buffer for pedestrians on fast-moving, multi-lane streets. Parked vehicles limit the effect of passing traffic from pedestrians on the sidewalk. The parking lane may also be configured to provide a variety of streetscape and pedestrian amenities, such as landscaping, bicycle parking and flexible use.

Guidelines

Narrow rights-of-way without sufficient space for both sidewalks and parking should prioritize the provision of sidewalks to meet recommended sidewalk widths per Section 4.2 of this document. Where sidewalks are not lined with parking, a buffer should be

provided with landscaping, bollards, and other amenities in order to physically and visually create distance between pedestrians and moving vehicles.

Materials

Where it is not precluded by heavy vehicles, the parking lane should be paved in concrete or special paving materials to match the pavement used on the adjacent sidewalk. Permeable paving such as pervious concrete or pavers should be considered. The parking lane may slope towards the roadway, such that the gutter is placed between the two. This may be considered on streets with curb extensions.





Attractive materials can distinguish the parking lane from other lanes. These pavers could be permeable, helping to reduce stormwater runoff.

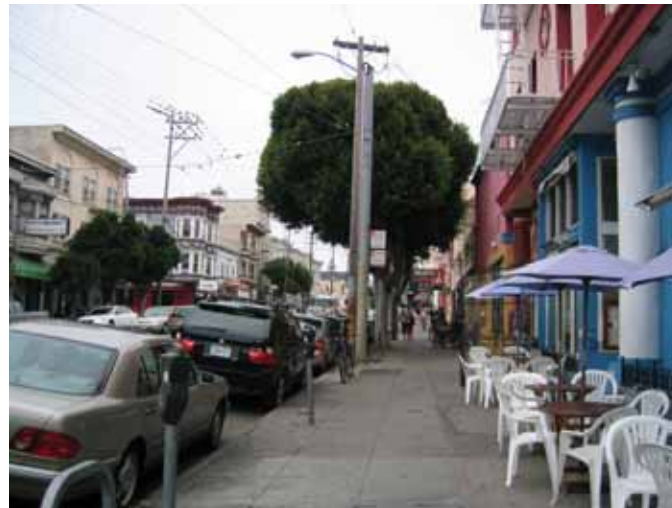

On-street parking is common throughout San Francisco's urban streets, and defines an edge of the pedestrian realm on many streets.

Perpendicular and Angled Parking

Perpendicular or angled parking lanes provide additional parking spaces while narrowing the vehicle travelway, which can have a significant traffic calming effect on the street.

Where perpendicular or angled parking is considered, there is an opportunity to create significant public spaces by adding curb extensions at either end that extend the full length of the parking. These may include landscaping, seating and other amenities, and should be used wherever possible when perpendicular or angled parking is used. See Section 5.3: Curb Extensions.

Alternative Uses for the Parking Lane

Parking lanes can be either temporarily or permanently converted to other uses, including bicycle parking and active pedestrian uses, such as café seating.

Landscaped Planters in Parking Lanes

Tree planters may be placed between parking spaces at regular intervals or at specific locations where street trees are limited by narrow sidewalks, location of utilities or conflicts with curb cuts. Because the roadway sub-base is typically 95% compacted, soil improvements should be used to avoid premature tree mortality.

Planters should not extend beyond the width of the parking lane and should be a minimum of 6 feet by 4 feet. See Section 6.1, Urban Forest for detailed guidelines.

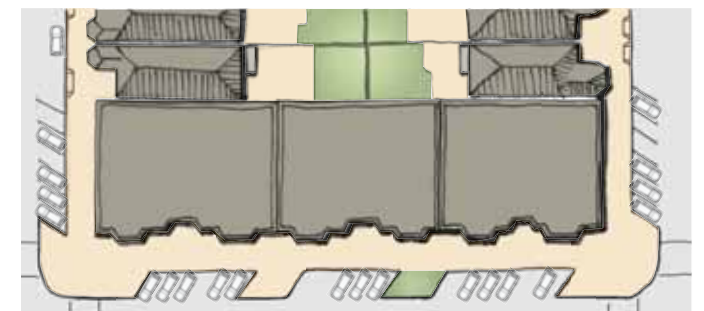
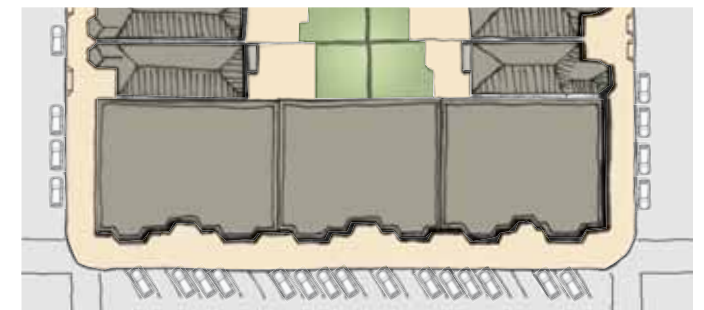

Perpendicular or angled parking lanes allow for the creation of generous corner plazas..

Trees placed in the parking lane can increase space for available greenery and visually narrow the roadway, calming traffic.



A parking-lane planter can be joined with a sidewalk planter below ground to create a more generous tree basin, with a continuous body of soil, though a gutter channel or runnel would be necessary for drainage in most locations. This gutter or runnel offers opportunities for stormwater infiltration, as it could drain through permeable pavers or a structural inlet to allow runoff to flow into planters.

Trees and planters in the parking lane should be protected from errant drivers by a bollard, raised curb, railing or other fixed object.

Where in-street planting is designed for stormwater infiltration, the curb may include breaks to allow stormwater to enter and overflow stormwater to exit when infiltration capacity is overwhelmed by the size of the rain event. See Section 6.2.

Tree canopies should be kept clear of conflict with passing vehicles in the near travel lane; they should be pruned to 14 feet.

Maintenance

Trees in parking lane require special maintenance considerations:

- They present a need for additional hand sweeping of gutter areas between the tree basin curb and the sidewalk curb
- They may present difficulties with repairing concrete pavement located between the tree basin and the sidewalk

Flexible Active Use of the Parking Lane

In many cases, particularly on downtown and commercial streets, the parking lane can be used for flexible active uses, such as for café seating, on a semi-permanent or temporary basis. Flexible use of parking lanes should be considered in commercial areas with high pedestrian volumes or numerous cafes and restaurants, or where these are desired in the future, as well as for individual cafes, schools, libraries and other local destinations.

Flexible use of parking lanes generally requires additional parking and merchant management, either by the City or by a third party such as a merchants association, Community Benefit District (CBD), or the like.

In general, the full width of the parking lane and as much as the entire length of a building's frontage should be made available to the adjacent business for flexible use.

Flexible space should be designed to instill a sense that the space is intended for people, rather than that pedestrians or café patrons are temporarily infringing on automobile space. Landscaping, special materials, and elements should be used to visually and physically break the parking lane down into independent, distinct spaces. Both permanent and temporary elements combine to create this space. These include:

Curb Extensions and Permanent Landscaping: On streets designed for flexible spaces, landscaped curb extensions or parking lane planters should be located at least every 5 parking spaces (a maximum of 100 feet apart). These should include large shade



Landscaped planters in the parking lane

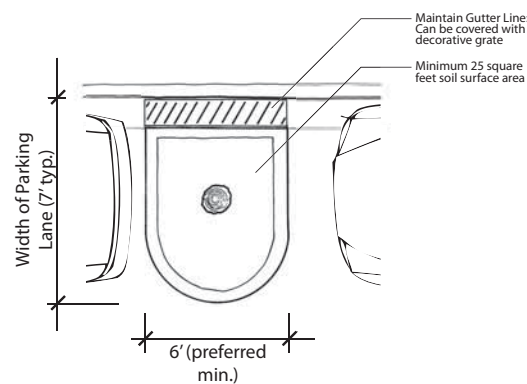

Top: Planting and trellises visually narrow the street and define "rooms" within the parking lane

Bottom: A stepped curb provides easier transition for pedestrians and visually signals to pedestrians that they are welcome to step into and use the parking lane.

trees, elevated planters, trellises, and other elements to define the visual character of the flexible spaces.

Special Paving Treatment: Colored and textured paving materials including paving stones should be used to differentiate these areas from the roadway. See Section 6.4: Paving.

Level Change: A level change of 1 to 2 inches should be introduced between the roadway and the flexible parking space in order to differentiate the spaces from the roadway. The curb between the parking lane and the sidewalk should be designed to include a stepped change in grade, rather than the standard 6” grade change. Flexible space should be made accessible to pedestrians with disabilities by the provision of additional curb ramps or other measures.

Safety considerations: Safety must be strongly considered when placing useable space in the parking lane. Locations for this treatment should be selected that have light, slow-moving traffic, narrow roadways, and a pedestrian character. Buffering elements should be provided for patrons. Moveable planters, bollards, or other elements should be placed at the roadway edge of the parking lane at times when it will be occupied by people. Elements should be relatively transparent, allowing people to see above or around them.

Flexible parking spaces should be placed so they do not conflict with other uses:

- Accessible parking spaces should not be converted to flexible use.
- Flexible uses of parking lanes should not obstruct the safe travel of bicycles in the adjacent bike lane.
- Flexible uses of parking lanes should not obstruct the safe travel of transit vehicles or the ability of passengers to board or alight vehicles.

Bicycle Parking in Parking Lanes

On-street automobile parking spaces may be converted to bicycle parking in locations with high demand. Bicycle parking may also be provided in the parking lane where there is not enough room to park a car, such as between driveways or between a hydrant and a crosswalk.

Bike racks should be placed such that parked bikes are perpendicular to the curb line. One 20 foot parking space can accommodate up to 12 bicycles on 6 U-racks without cluttering limited sidewalk space.

Where possible, bicycle parking should be built on a curb extension. Where implemented at the existing grade, the bike parking area should be protected from errant vehicles via a curb, bollards or other devices at the edge of the parking lane. On-street bicycle parking would preclude mechanical street sweeping, and additional maintenance should be accounted for.

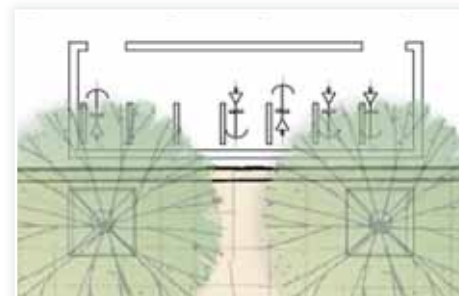

Where there is a high demand for bicycle parking, on-street spaces can be converted into bicycle parking areas to provide substantially more bicycle parking and reduce sidewalk congestion.



**BEST PRACTICE:
CASTRO STREET FLEXIBLE PARKING**

MOUNTAIN VIEW, CALIFORNIA

As part of a larger downtown revitalization effort, the City of Mountain View converted a 4-lane arterial into a 3-lane pedestrian-oriented main street. In addition to widening sidewalks and adding unique paving and extensive planters, the City installed flexible parking lanes on either side of the street. These areas use urban design details such as attractive paving and trees and planters on bulbouts to define the shared pedestrian and parking space. Cafes along Castro Street spread tables into the parking stalls in front of their businesses during business hours, allowing patrons to sit under the trees and watch city life go by. This project was a major part of bringing business and life back to the town center, and has resulted in a number of cafes with outdoor seating and more people walking on the streets and patronizing local businesses.



Paris and Lyon (above/below respectively) are among the cities that have implemented bicycle-sharing programs. To provide the necessary space for the many new bicycles, on-street parking space may be converted for use as bicycle parking. (Source: Elizabeth Macdonald)

BIKE SHARE PARKING

San Francisco is considering implementing a bicycle sharing program similar to programs in Paris, Lyon and Barcelona. If San Francisco implements bicycle-sharing, conversion of some automobile parking spaces to bicycle parking could help accommodate the storage racks which hold as many as 20-30 bicycles.

BEST PRACTICE: BERKELEY, CALIFORNIA

In Berkeley an on-street parking space on Center Street was converted from an automobile space to bicycle spaces to add more bicycle parking without cluttering or obstructing the sidewalk. The City's bicycle plan identified a lack of adequate bicycle parking as a major deterrent to people biking downtown. Because a set of bicycle racks can accommodate more visitors than the single car that would park in the space, the City decided this was a worthwhile conversion at one of the most important retail corners in the city.

The original design of the space specified a different paving treatment than the surrounding street to stand out from the normal roadway and parking (this detail was not included in the final built space, however). It also includes bollards as a visual cue to drivers and cyclists, and to provide protection for bikes. The bollards are spaced to easily allow bikes to enter and exit and cyclists to park and load/unload their bicycles without having to stand in traffic.

Design dimensions are shown below:

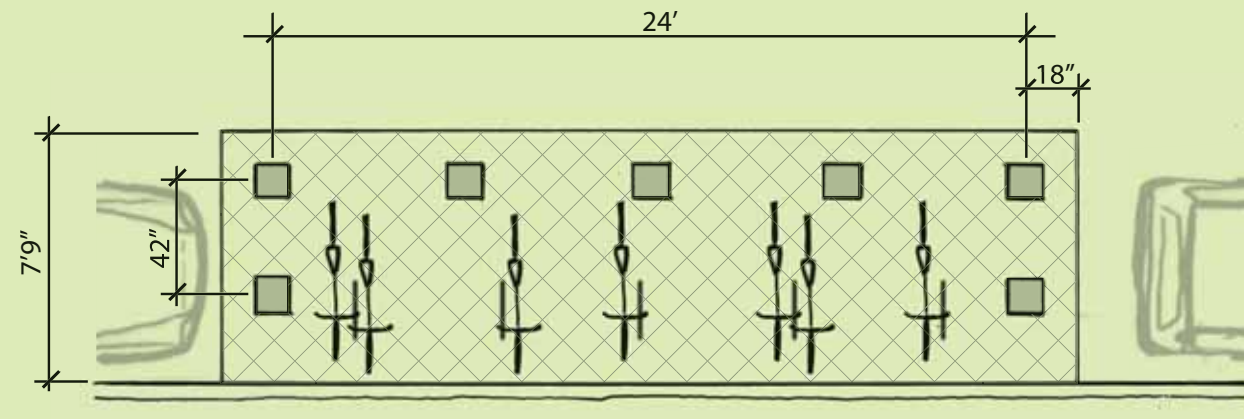

Courtesy City of Berkeley Department of Public Works, Downtown Pedestrian Corridor Center Street Streetscape Improvements. Design by Merrill + Befu Architects with Lyndon Buchanan Associates.

By affecting vehicle speeds, volumes, and trajectories as well as streetscape composition, traffic calming measures can have a tremendous effect on both the safety and quality of the pedestrian realm.

5.7

TRAFFIC CALMING AND ROUNDABOUTS

By affecting vehicle speeds, volumes, and trajectories as well as streetscape composition, traffic calming measures can have a tremendous effect on both the safety and quality of the pedestrian realm. Many of the topics discussed in this plan, such as street trees or decorative paving, have potential traffic calming benefits. The list of traffic calming devices available to those who plan, design and engineer our streets is lengthy and is covered fully in many other resource documents. The intent of this document is not to discuss all potential traffic calming devices.

This section focuses on chicanes, traffic calming circles, and modern roundabouts as representative traffic calming devices, because of their potential synergies with streetscape design, land-

scaping, and stormwater treatment, and because unlike diverters, turn restrictions, cul-de-sacs, one-way streets, or other measures, they reclaim roadway space for landscaping and other uses without significantly affecting traffic patterns and roadway vehicle capacity, which would go beyond the scope of this plan.

Some related traffic calming measures are discussed in other sections of this document, including:

- Raised crosswalks and intersections (Section 5.1)
- Curb extensions (5.3)
- Medians and islands (5.4)



The City has existing adopted Traffic Calming Guidelines, which govern appropriate traffic calming procedures and measures (see sidebar).

General Guidelines

Traffic calming features should follow San Francisco’s existing Traffic Calming Guidelines. Features discussed in this plan should incorporate landscaping, stormwater treatment, and public space uses wherever possible.

Traffic calming features should be compatible with transit operations. See Section 5.5.

They should also consider emergency vehicle access requirements. See Sidebar.

Chicanes

A chicane is a series of alternating mid-block curb extensions or islands that narrow the roadway and require vehicles to follow a curving, S-shaped path. Chicanes can be used on one-way or two-way streets and can be single lane or two-lane configurations. They have the streetscape benefit of adding significant new spaces for landscaping and urban design detail in the roadway.

Chicane

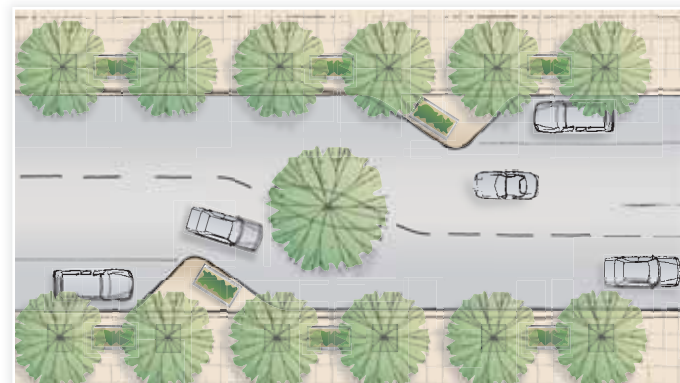

Guidelines

Chicanes can be created on roads with two travel lanes and one parking lane or with two travel lanes and two parking lanes, as follows:

- On streets with parking on only one side, chicanes can be created by alternating parking from side to side. Chicanes can also be formed by alternating parallel parking and perpendicular parking. Curb extensions should be included at each end of on-street parking.
- Where a wide right-of-way allows, parking may be maintained on both sides of the street through the entire chicane, and the entire roadway can jog from side to side using curb extensions.

SF TRAFFIC CALMING GUIDELINES

San Francisco’s existing Traffic Calming Guidelines were developed collaboratively by a staff Technical Working Group and a Community Working Group. The Traffic Calming Guidelines are largely procedural, and are based upon a three-track approach:

- A track for arterial and commercial streets, using a corridor approach
- A local street track with an area-wide focus, and a local street track with a site specific focus, with a streamlined process
- A site-specific track for safe routes to school

The Traffic Calming Guidelines provide a table of traffic calming measures that indicates which measures are acceptable on which types of San Francisco streets. However, they do not provide standard plans or detailed design guidelines for individual measures. The City has standard plans for traffic circles and speed humps, but not for other traffic calming features.

As a follow-up item to this plan, the City should work to develop standards for traffic calming measures.



Chicanes slow vehicles by causing them to slightly change path. They add opportunities for landscaping to improve street aesthetics. (Source: Mike King)





Traffic circles slow traffic in residential neighborhoods and provide added space for landscaping and stormwater infiltration.



Traffic circles should include landscaping, including trees, and permeable surface. They may be designed to infiltrate stormwater runoff from the roadway.

Chicanes in both conditions may include a median island at points of deflection to prevent speeding drivers from continuing straight down the center of the chicane, disregarding roadway markings.

Median islands and curb extensions (in chicanes as elsewhere) should include landscaping and may include seating and stormwater treatment wherever possible.

Because proper design of chicanes is intended to slow all vehicles, consideration must be given to performance of emergency vehicles. Emergency vehicle operators typically prefer the installation of chicanes to speed humps in terms of performance limitation, but the Fire Department in San Francisco has not expressed a preference.¹ Chicanes must maintain the required clearances for emergency vehicle access, which in San Francisco is 20 feet on a two-way street.

Chicanes should not be located on streets with Rapid or Local bus service. If chicanes are desired on streets with buses, the chicane should be located at a bus stop so that the impact on transit service and passenger comfort is minimized.

Standard CA MUTCD formulas for calculating taper lengths for striping around any horizontal offset caused by obstacles in the roadway typically yield tapers that are so long that they negate the traffic calming benefits of chicanes and other traffic calming devices that work with horizontal deflection. In order to achieve the desired speed reductions, chicanes should be designed using formulas for lower speeds than are actually desired on the street.

¹ <http://www.ite.org/traffic/chicane.htm>

Traffic Calming Circles

A traffic calming circle is a raised island located in the center of an intersection around which traffic must circulate. By providing a permeable landscaped area in the middle of the roadway, they can visually break up the scale of wide streets, break up the monotony and predictability of the street grid, and provide space for added greenery and stormwater treatment. The outer ring is usually mountable so that large vehicles can navigate the otherwise small curb radius. Traffic calming circles are generally used at low volume neighborhood intersections.

Traffic calming circles should not be confused with roundabouts, which are designed to handle much higher traffic volumes and reduce vehicle delay. However, they have a similar positive effect of significantly reducing conflicts (see figure).

Placement

Traffic circles should be located on streets where it is desirable to calm traffic and reduce conflicts, such as residential streets. Traffic circles should not be located on transit routes.

Guidelines

Traffic circle design in San Francisco follows DPW Bureau of Engineering's standard plan for Traffic Circle Details. However, intersection geometry varies greatly, and the standard plan may need to be adjusted for different conditions. Traffic calming circles should maintain sufficient space such that vehicles do not swing into crosswalks. This may mean setting crosswalks back or redefining crosswalk edges where space permits.

The City should develop additional standard plans as traffic calming circles become more common in the city.

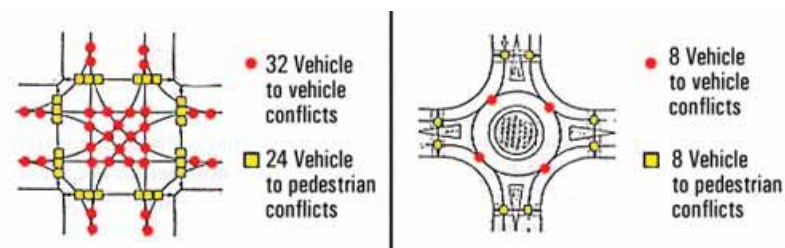

Conflict points at traffic calming circles (and roundabouts). Source: Stidger, Ruth "Can America Handle Roundabouts," Better Roads, May 2003

**BEST PRACTICE:
SEATTLE, WASHINGTON TRAFFIC CIRCLES**

The City of Seattle has installed over 700 traffic circles on residential streets as part of a citywide plan to reduce auto volumes and speeds in residential areas. The circles are so popular that the City receives approximately 700 requests for new circles each year, and installs 30 per year at a typical cost of about \$10,000 each.

Two key design features of the traffic circles are that they are large enough to force cars to slow down to go around them and that the centers are attractively landscaped. The outer two feet or so of the circles is a concrete apron, with a low four-inch curb that emergency vehicles can go over easily when necessary. Typical

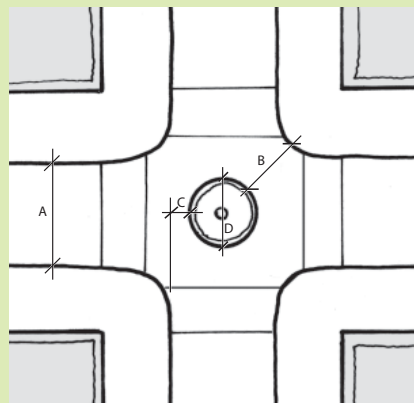

A - Street Width: Existing
B - Opening Width: Typically 16-20 feet
C - Offset Distance: 5.5 feet max. (varies)
D - Diameter: Typically 12-20 feet

OPTIMAL DIMENSIONS	
Offset Distance	Opening Width
5.5' (max)	16' (min)
5.0'	17' (+/-)
4.5'	18' (+/-)
4.0'	19' (+/-)
3.5' or less	20' (+/-)

traffic circles on a 25 foot wide residential street range between 12 and 16 feet wide.

The circles typically include 1 or 3 trees as specified in the landscaping guidance above. Additionally, neighborhood residents can plant lower brushes and shrubs in the circles. The City encourages planting of drought-tolerant and low-maintenance plants and publishes a list of suggested trees and planting for traffic circles. Landscaping in the traffic circles is maintained by local residents

Source: City of Seattle, Seattle Transportation (SEATLAN)

DESIGN DIMENSIONS

The distance between a traffic circle and the street curb projection (off-set distance) should be a maximum of 5-1/2 feet.

The width between a traffic circle and a curb return (opening width) should be a minimum of 16 feet and a maximum of 20 feet.

As the off-set distance decreases from the maximum 5 1/2 feet, the opening width should increase from the minimum of 16 feet according to the table below.

The outside 2 feet of the traffic circle should be constructed with a mountable monolithic cement concrete curb and pavement surface doweled to the existing pavement.

TRAFFIC CALMING AND EMERGENCY ACCESS

Emergency vehicle access is often a determining factor in street design and traffic calming projects. Emergency access standards can impact a number of design features recommended in this plan.

Emergency service providers may be concerned about traffic calming features, such as chicanes or speed humps, that may slow emergency response time.

On most streets sufficient width exists as a matter of course. However, some treatments discussed in this plan may conflict with minimum width or response time requirements, including traffic circles, chicanes, medians and islands, shared streets, and local lanes of multi-way boulevards.

In some cases, design techniques may be employed to mitigate impacts on emergency access, for example, by providing mountable curbs or aprons at the edges of traffic circles or medians. In other cases, proposed design features may not work at all, and may have to be eliminated from proposals.

In all of these cases, achieving good street design while maintaining necessary emergency access requires further discussion between agencies that design and build streets and emergency service providers. The City should create a forum to focus on this issue.



Roundabouts are typically larger and more formal yield-controlled intersections than traffic circles. The larger center island and multiple medians provide ample opportunity for planting and stormwater management.

Traffic calming circles should be large enough that vehicles entering the intersection must slow down and change course, but should not significantly alter the path of travel for pedestrians or bicyclists. The size of traffic calming circles should be determined based on the width of the adjoining streets. The installation of traffic calming circles does not usually require a change in curb geometry.

Pedestrians using the crosswalk may feel threatened when vehicles swing wide at the intersection to avoid the center island, pointing toward the crosswalk. In properly designed circles, vehicles navigating the intersection will not intrude into the pedestrian crossing area. A minimum of 11' of clearance between the circle edge and the crossing location should be used per standard plans. To provide proper clearance, it may be necessary to move the crosswalk back; however, this can lead to poor alignment with the curb ramp and may ultimately preclude installation of traffic circles in narrow intersections.

Traffic calming circles may be stop- or yield-controlled and should be signed to indicate the direction of circulation.

Traffic calming circles should be designed with both a vertical inner curb and a mountable apron per standard plans. The vertical inner curb prevents vehicles from driving over the circle. The apron is a shallow sloped curb extending out from the bottom of a vertical curb, with a low lip at its pavement-side edge. This apron effectively reduces the diameter of the center island, facilitating turns for large vehicles. The lip at the apron's edge discourages vehicles from using it unnecessarily.

Traffic calming circles at T-Intersections: Traffic circles should have deflection on all approaches if implemented at a T-intersection. This can be implemented on both existing streets in retrofit situations and on newly constructed streets. At an existing T-intersection, a raised island can be placed at the right side of the un-deflected approach to the traffic circle to artificially introduce deflection. With new construction, the street curbs can be modified to allow the center island to be located at the center of the intersection. (See Diagram)

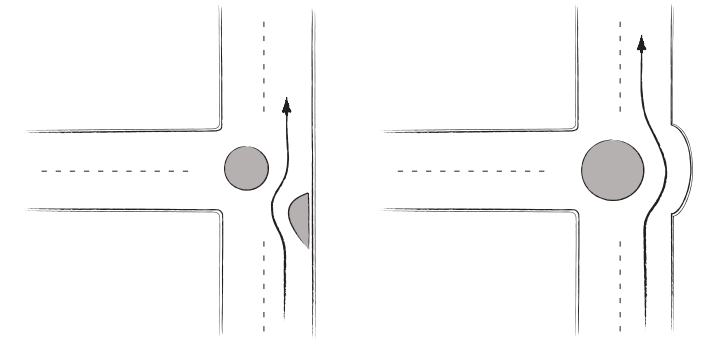

Traffic circles at retrofit and new T intersections. Source: Placer County Neighborhood Traffic Management Program, Placer County Department of Public Works, February 2007

Despite their name, traffic calming “circles” need not be circular. Another shape can be used to slow traffic in one direction more than others, for example where a busy street intersects with a residential area where traffic should be slowed down and calmed.

Traffic calming circles should be landscaped with trees or plantings. Shrubs and grasses should be planted up to 3 feet tall and trees should follow the branching height and pruning guidelines described in Section 6.1, Urban Forestry.

Trees should be planted a minimum of 4 feet from the inside edge of the curb. In traffic calming circles with a diameter of less than 15 feet, one tree should be planted in the center. On a traffic calming circle with a diameter greater than 15 feet, more than 1 tree should be planted and should be equally spaced around the circle.

Traffic calming circles added by neighborhood request should consider added maintenance burdens; this may require maintenance agreements with adjacent property owners.

Utilities may remain within traffic calming circles in order to minimize costs.

Modern Roundabouts

Roundabouts are used at intersections in place of signals and can handle significant traffic volumes. Although their primary purpose is to provide motor vehicles free flowing mobility, properly designed roundabouts can create a positive environment for pedestrians, as well as a unique design treatment.

Roundabouts have lower vehicle speeds and fewer pedestrian collisions than standard signalized or unsignalized intersections, and experience has demonstrated that vehicular crashes are significantly reduced when low-speed, single lane roundabouts replace four-way intersections.¹

When vehicular volumes are low to moderate, roundabouts allow pedestrians to cross frequently without waiting for vehicles to stop. However, crossing pedestrians are not protected since vehicles are free flowing. Modern roundabouts incorporate splitter islands to provide crossing refuge for pedestrians and deflect the path of motor vehicles. This deflection reduces vehicle speeds making it easier for pedestrians to cross. Because they introduce non-standard geometry to the intersection, roundabouts can be confusing to pedestrians with visual impairments and special care must be taken to provide wayfinding cues (see sidebar).

¹ *Context Sensitive Solutions in Designing of Major Urban Thoroughfares for Walkable Communities*, Institute of Transportation Engineers Proposed Recommended Practice

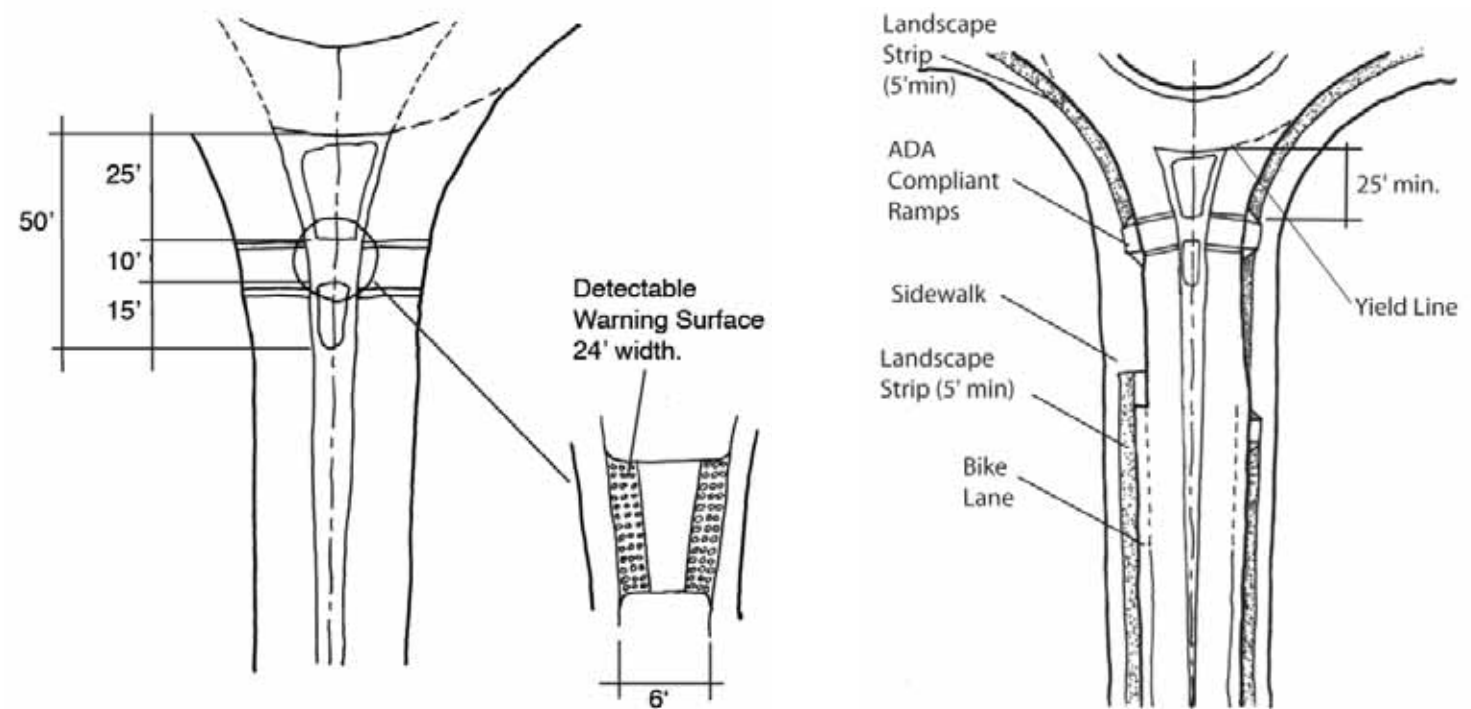

Crossings at roundabouts should have splitter islands and be set back from the intersection

NOTE: In general, roundabouts have limited application in San Francisco due to the typical constrained conditions at many intersections and on-going debate as to their appropriateness for pedestrian-oriented environments. At some larger intersections with unusual traffic alignments and high traffic volumes they may be considered to improve capacity and roadway function. This section is intended to address safe and attractive design of roundabouts for pedestrians and bicycles and local residents and business owners, where it is determined that a roundabout is to be implemented, not on transportation and traffic management functions, though these are alluded to in explanation of roundabout function. For additional detail on traffic engineering and design considerations, see *Roundabouts: An Informational Guide* published by the Federal Highway Administration.

ROUNDABOUTS AND PEDESTRIAN WAYFINDING

Modern roundabouts present challenges for pedestrians with visual impairments because vehicles are not required to stop at an intersection with a roundabout as at a conventional intersection. Visibility of crosswalks and detectable entry points of crosswalks must therefore be carefully considered and should be addressed through appropriate signage and higher visibility crossing treatments. Signage indicating the presence of the pedestrian crossing is recommended to remind drivers that while they are only required to yield to traffic within the roundabout, they are required to stop for pedestrians that are in the crosswalk.

Wayfinding and gap selection cues should be incorporated into the design of roundabouts so they do not become a barrier to pedestrians with visual impairments. Detectable warning strips should be used at all pedestrian crossing entry points. Sidewalks should be set back from the edge of the circulatory roadway by at least 5 feet so that pedestrians with visual impairments can clearly follow designated crossing points. This also serves to discourage pedestrians from crossing to the center island and provides space for landscaping.

Research into how better design roundabouts for pedestrians with visual impairments is currently underway by the National Cooperative Highway Research Program (NCHRP) and should be incorporated into designs when its findings are released.

Placement

Roundabouts have limited applicability in San Francisco.

Roundabouts are appropriate to medium to high volume intersections that would otherwise have some other form of intersection control, such as a four-way stop or traffic signal. Modern roundabouts may be considered under the following conditions:

- intersections with more than four intersecting streets;
- high volume grade-separated intersections where there is a desire to bring streets back to surface level to create at-grade intersections;
- intersections with freeway on and off ramps as appropriate.

Many typical San Francisco site-specific conditions may preclude installation of a roundabout, including: physical and geometric constraints; proximity of other traffic control devices that would require preemption (e.g. railroad tracks or Rapid transit routes); high numbers of oversized trucks; and heavy pedestrian and bicycle movements in conflict with high vehicle volumes.

Guidelines

Crossings at intersections with modern roundabouts should be carefully designed to minimize pedestrian exposure to vehicles, using the following techniques:

- Crossing distances should be minimized
- Unobstructed sight distance between crosswalks and approaching traffic should be provided.
- At single lane roundabouts, the pedestrian crossing should be at least one vehicle length (at least 25 feet) from the yield line at the intersection with the roundabout to allow one car to queue beyond the crossing.

- At double lane roundabouts, the crossing should be at least 50 feet from the yield line.
- Splitter islands should be provided. If there are to be pedestrian refuges, they should meet the guidelines in Section 5.4: Medians and Islands.

Center islands should be landscaped with planting less than 3-foot tall within 4 feet of the edge of the curb and may be considered for large public art installations such as fountains that would create a gateway to major civic locations or to the City from highways. In some cases, useable public space may be designed to be within the center island.

Transit Stops

Transit stops located on the near side of the roundabout should be located far enough away from the splitter island so that a vehicle overtaking a bus is in no danger of being forced into the island. For a single lane entry where capacity is not an issue the transit stop can be located at the crosswalk. Transit stops on the far-side of the roundabout should be located beyond the pedestrian crossing and have pull-outs constructed to minimize queuing in the roundabout.

Bike Lanes

Bicyclists may be disadvantaged by roundabout design, and marked bicycle lanes through roundabouts have not been shown to improve safety.¹ Bike lanes should be terminated in advance of crosswalks at roundabouts. For one-lane roundabouts with slow speeds and light traffic, bicyclists may merge into the vehicular travel lane comfortably. At multilane roundabouts, which are far more challenging for cyclists to navigate, additional safety and design features should be provided.

¹ *Roundabouts: An Informational Guide*, US Department of Transportation, FHWA, 2000. Chapter 5 Safety, Section 3.3 Crash Statistics, Bicycles



5.8

PEDESTRIAN-PRIORITY DESIGNS

Pocket Parks

Pocket parks are small, active public spaces created in the existing public right-of-way. They can be located in medians, curb extensions, or in the furnishings zone on sufficiently wide sidewalks. In addition to landscaping, pocket parks should include seating areas, play areas, community garden space or other elements to encourage active use of the public open space. Pocket parks provide important public space in areas with high-density land use and areas deficient in public spaces.

Guidelines

Pocket parks should be designed as modular spaces that provide for a variety of useable and replicable open space functions

including active and social activities, in addition to ornamental functions. These modular spaces may include: seating, café tables, play or fitness equipment, open lawn space for play and relaxation or dog runs, community gardens, ecological/educational displays, or community bulletin boards.

Pocket Parks should be landscaped or use special paving materials to differentiate their unique open space function from the normal sidewalk or median.

A buffer should be created between pocket parks and passing traffic for the safety of all users, especially children. This buf-



fer can be landscaped, such as a hedge, or constructed, such as bollards, a low fence, or a low wall (with integrated seating). The buffer should generally not be higher than 30-inches.

Pocket parks may be designed to serve as stormwater retention and infiltration areas following major rain events. Pocket parks should be terraced along steep streets to maintain ADA access and provide areas for sitting and recreating.

Sidewalk Pocket Parks

Sidewalk pocket parks should be a minimum of 15 feet long and preferably at least 20 feet wide. Specific dimensions should be determined based on the width of the public right-of-way, space between driveways, and the needs of the surrounding street and neighborhood.

Where on-street parking at curbs is provided, an 18 inch minimum vehicle egress area (courtesy strip) should be included on the curb side to allow vehicle passengers to access parked cars. A 4-foot walkable pathway should be provided at intermittent distances of no more than 40 feet to allow access between the vehicle egress area and the primary sidewalk throughway.

Median Pocket Parks

Median pocket parks should connect to the primary pedestrian network through marked crossings at each end and, on long blocks, at a mid-block crossing. Bollards should be provided at the ends of the median to define the edges of the park space and create a formalized, special entrance.

Median pocket parks should extend the full length of the block or as long as space allows.

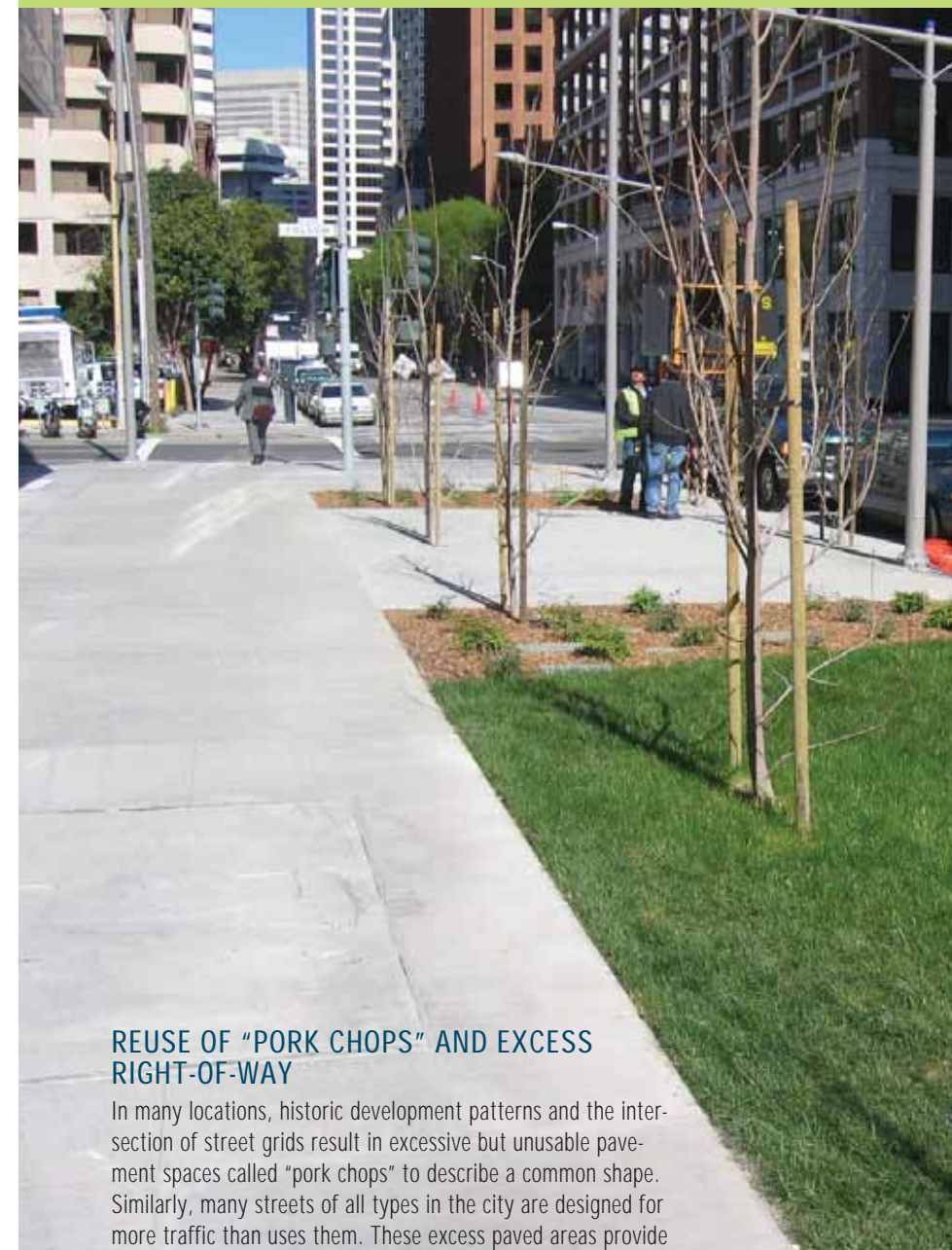

REUSE OF “PORK CHOPS” AND EXCESS RIGHT-OF-WAY

In many locations, historic development patterns and the intersection of street grids result in excessive but unusable pavement spaces called “pork chops” to describe a common shape. Similarly, many streets of all types in the city are designed for more traffic than uses them. These excess paved areas provide many opportunities for pedestrian improvements, landscaping, and active uses.

Pork chops and unused intersection spaces should be brought to sidewalk level and should include landscaping, seating and active uses wherever possible. These spaces can be used to create bosques, rain gardens, creative paving, public art, and many other important amenities.

Each case is unique, but even small spaces can be effectively used for local improvements:

- 25 square feet can be enough for healthy tree planting and even less is necessary for corner landscaping;
- a few feet of roadway width along a street can provide space for a swale or landscaped strip;
- a 7 foot extension at a corner can provide space for seating areas

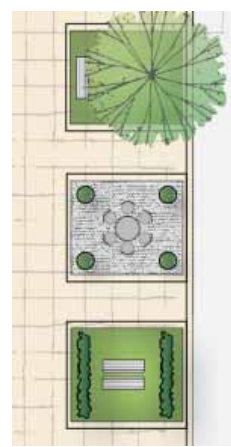

Pocket parks can be created in both medians and sufficiently wide sidewalks



The Duboce Triangle neighborhood includes a number of small sidewalk pocket parks.



This median includes a pedestrian and multi-use path lined with substantial landscape buffers where people can sit and relax. (Source: Mike King)

Median pocket parks should be a minimum of 12 feet wide and 24 feet long, including:

- An accessible pedestrian path, 4 feet or wider, connected to intersection and mid-block crossings
- A minimum 18 inches of buffer on each side of the median such as landscaping or bollards
- A minimum of 5 feet of seating, planting or other amenities

Median pocket parks should exceed these minimum standards as width allows for the setting and intended use of the space. A more flexible approach to the edge of the median can be taken on streets with low traffic volumes and speeds, where a lesser buffer may be necessary. In these cases, special design and paving treatments may be continued through the roadway to emphasize the pedestrian-oriented nature of the space.

BEST PRACTICE: SANDY BOULEVARD CORNER TRIANGLES PORTLAND, OREGON

Similar to San Francisco, Portland has a grid-based street system with some streets that break the pattern resulting in small spaces at odd corners. On one such street, Sandy Boulevard, these triangular spaces were previously left unpaved, resulting in some

crossings of over 100 feet. The curbs have been extended to narrow these crossings, and the resulting sidewalk spaces have been converted to stormwater gardens, public parks, and cafes.



San Francisco's South Park is a median pocket park that includes benches, green space and a children's play area.



Courtesy City of Portland's Department of Transportation and Bureau of Environmental Services. Design by Nevue Ngan Associates, URS Engineering, and Lloyd Lindley, FASLA.

Pedestrian Design for Boulevards

Boulevards are designed to separate traffic moving through a neighborhood from local traffic and neighborhood uses. Many existing San Francisco streets may be appropriate for conversion to boulevards. Boulevards can improve the experience of the street for all users, and benefits include:

- Local access lanes make travel safer and easier for both through traffic and local traffic by separating these two functions.
- Local access lanes can be used as a shared space for local use: for making deliveries, for children to have a small residential street to bike on within the larger city street, for pedestrians to walk in, or for local businesses to temporarily use for special events with a street closure.
- Multiple medians and roadways create the opportunity to add many design features, such as multiple rows of trees, areas of special paving, and various areas for walking or sitting.

A multiway boulevard, such as Octavia Boulevard, has local access lanes on each side of the street. A one-side boulevard involves the installation of a local access lane on only one side of the street, where this is justified either by a constrained right-of-way or the land use context on each side of the street.

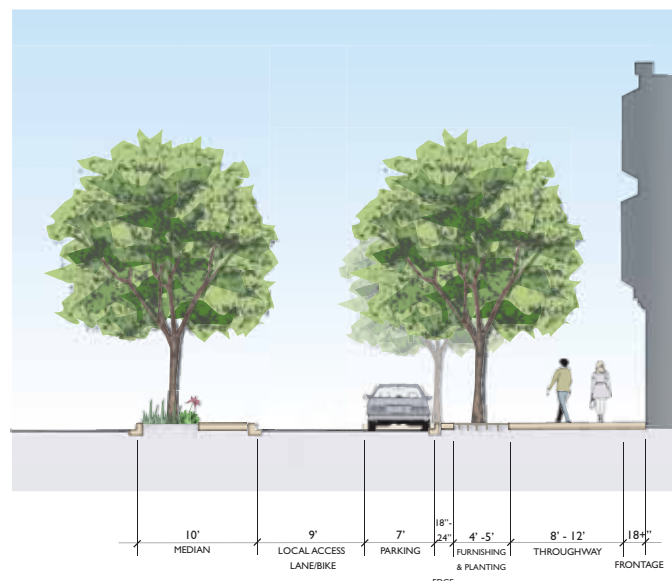

Boulevard treatment should be considered for streets that serve both local traffic and significant through traffic and have sufficient right-of-way (generally more than 100 feet, though a minimum width could be as low as 86 feet).

Guidelines

Boulevards should be designed to clearly demarcate local community space from through traffic. Side medians, local access lanes, parking and sidewalks should be considered community space and should feature pedestrian-scale design.

Medians should establish a boundary between through traffic and the neighborhood-oriented space and should include landscaping and tree plantings. The preferred width for side medians is 10 feet. Side medians designed for landscaping should be a minimum of 6 feet wide, including curbs. Even if side medians are not designed for active use, they should include a solid surface to allow pedestrians to use them. In order to provide the required 14 feet of emergency access clearance, a mountable curb may be provided.

Community space in boulevards (including the median, local access lane, parking lane and sidewalks) should include the following elements:

- A slight grade change (1-2 inches) from local access lane to the median and the sidewalk
- Special paving throughout the local access lane (Section 6.4)
- Raised crossings at the ends of each block (5.1)
- Curb extensions at all corners (5.3)

The community space on a multi-way boulevard may also use a shared street design, with the entire shared space at a grade higher than the through travel lanes. Shared space in boulevards should follow the guidelines for shared streets in Section 5.8, Pedestrian Priority Designs.

Parking may be located on either the median or the sidewalk side of the local access lane and can be parallel parking or angle parking.





Side medians, such as those created on Octavia Boulevard, should be designed as pedestrian space. The local access lane should be designed similarly to reflect its orientation to pedestrians to provide a larger usable space for adjacent neighborhoods and businesses.

BEST PRACTICE: OCTAVIA BOULEVARD

SAN FRANCISCO, CALIFORNIA

Octavia Boulevard is the focal element of a larger neighborhood revitalization project in San Francisco's Hayes Valley district. Extensive stakeholder outreach, design charrettes, and collaboration with City agencies led to the development of San Francisco's first multiway boulevard. The boulevard includes an ample pedestrian realm, active recreational areas, substantial landscaping and green space in a right-of-way that was formerly an elevated freeway. In the time since its completion, a number of blocks along the street have undergone new construction and the addition of many new businesses.

The local access lanes of Octavia Boulevard are a case of mixed success. Many design elements including the multiple rows of trees are attractive and effective. However, to accommodate emergency vehicles and parking and driveway access, the lanes were built too wide to effectively discourage through traffic from speeding down them. As a result, these lanes feel like any other street, rather than shared space meant for local and neighborhood use. Narrower lanes, special paving, raised crossings and curb extensions would discourage frequent traffic and slow the traffic that does pass through, allowing local residents to confidently venture out into this space and use it and the side medians.

There are two design treatments for crossings at intersections along multi-way boulevard, shown below:

Alternative 1: A large corner bulb-out provides space for seating, landscaping or other amenities, and discourages through travel in the side access lanes by causing traffic to re-enter the through traffic lane at each intersection.

Alternative 2: The side median extends into the intersection to create a pedestrian refuge island with a thumbnail at the intersection end. This allows a continuous traffic flow in both the through traffic lane and in the side access lanes.

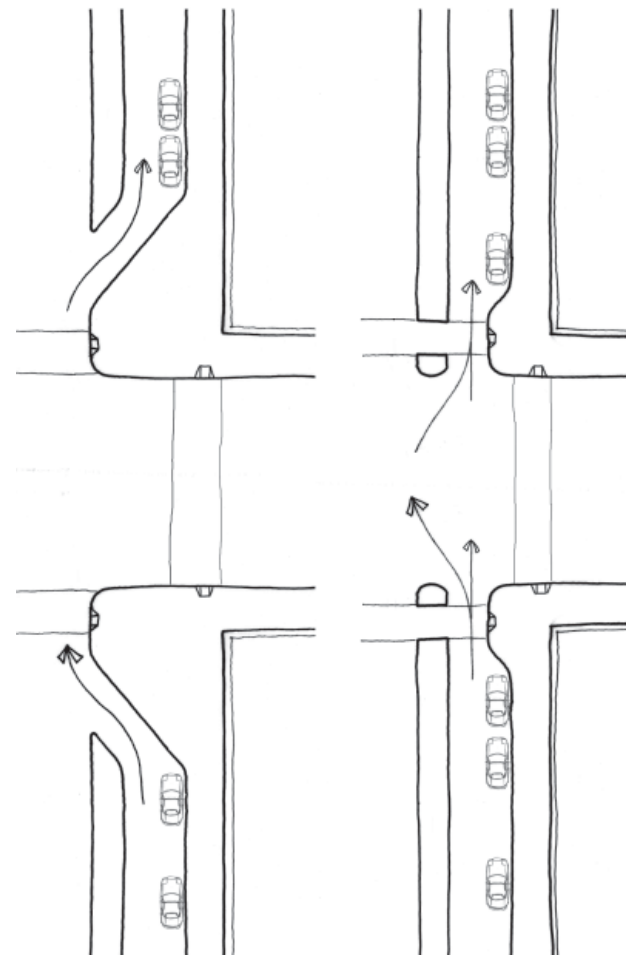

Alternative 1

Alternative 2

Transit Stops at Boulevards

On streets with transit, transit vehicles can be accommodated in the right-most through travel lane of the central road-way by placing the transit stop and amenities on the side median. Transit vehicles can also operate in the local access lane if a wide enough travel lane is provided, however this may result in potentially slower transit performance, and increased traffic in the local access lane, which can negate the neighborhood space function of this space.



Placing parking on the median side of the local access lane can improve connection between the sidewalk and the local lane, and better buffer the sidewalk and shared area from the higher-volume thruway lanes.

Shared Streets

Shared streets are right-of-ways paved as one single surface and grade so that the entire space is shared between pedestrians, bicyclists and vehicles. Shared streets function as a pedestrian-oriented yard, plaza or open space where pedestrians are encouraged full use of the entire space. Vehicles are allowed, but must proceed slowly to their destinations. Amenities and landscaping are designed and organized to encourage the use of the street as shared neighborhood open space, primarily oriented to the pedestrian.

Shared streets are appropriate to areas where pedestrian volume and neighborhood use of street space outweighs vehicular traffic needs, but where auto access is necessary and can be accommodated at a very slow pace. Shared streets should be prioritized in areas without nearby parks, useable public space, or community gardens, and can be used to create these community spaces in the public right-of-way.

Shared streets should not be implemented on streets with transit functions except in the case of a pedestrian and transit mall or other street closed to all other vehicular traffic.



Shared streets improve mobility for pedestrians by removing curbs, allowing people to move more freely throughout the entire right-of-way. (Photo: Ellen Vanderslice, Portland Office of Transportation)

Guidelines

The entrance to shared streets should be designed to alert drivers, bicyclists and pedestrians that they are leaving an auto-oriented road space and entering a pedestrian-oriented shared space. Elements that should be used to signal this shift include:

- Raised crosswalks located at every street entrance
- Signage alerting drivers to the unique pedestrian nature of the shared street
- Design elements such as special planters to create a gateway to the shared street

Shared streets should be paved in attractive pavers or pavement patterns to reiterate the unique pedestrian- and neighborhood-oriented function of the space to drivers and pedestrians.

Paving materials should be in a continuous pattern across the right-of-way. However, paving should create a contrast, either light-on-dark or dark-on-light (per accessibility standards) between the shared roadway and pedestrian-only areas.



Single-surface treatments create unique opportunities for special pedestrian-scale design and amenities, added landscaping, and special spaces within the right-of-way. (Photo: Ellen Vanderslice, Portland Office of Transportation)

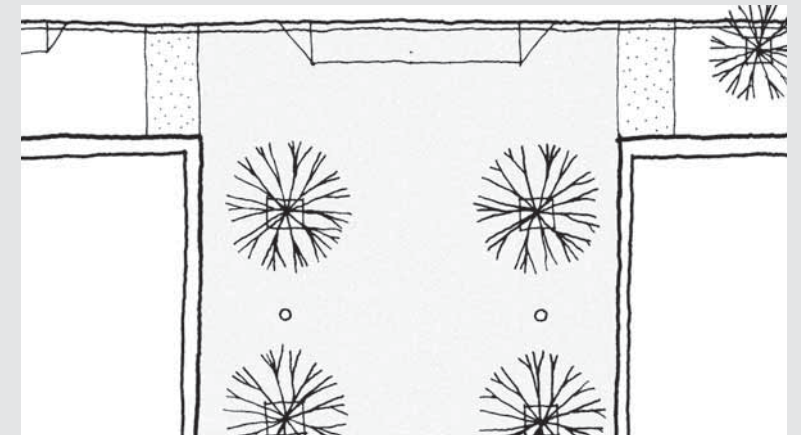

Detectable warnings at the entry or 'blended transition' to shared streets indicate an entrance to a place where one may encounter vehicles, in lieu of a curb or ramp

5.8 PEDESTRIAN-PRIORITY DESIGNS



Special paving treatments, landscaping, and other elements can be used to delineate spaces within the right-of-way

Pedestrian-only areas should be further separated by evenly spaced bollards, planters, benches, or street furnishings such that the space is distinguishable as pedestrian-oriented, but spaced widely enough to allow ease of movement between the spaces and visual continuity.

Vehicular traffic should be calmed on shared streets using design elements to create chicanes, which shift vehicles from one side of the space to the other as they travel. See Section 5.7 for chicane guidelines. Chicanes should be created by using streetscape elements, including trees and other landscaping, bollards, or useable neighborhood spaces such as play equipment or seating.

The unique pedestrian and public space character of shared streets can be reinforced through landscaping. Planters can define distinct spaces within the right-of-way, such as sitting areas, play areas, parking and the edges of the travelable roadway for vehicles. Stormwater infiltration landscaping can be placed in the shared right-of-way in locations where it does not conflict with underground utilities or other infrastructure.

Emergency vehicle access must maintain a minimum of 14 feet clearance for a one-way street and 20 feet for a two-way street.

Drainage should flow away from buildings, either toward the center of the street, or with a side running gutter on either side of the roadway.

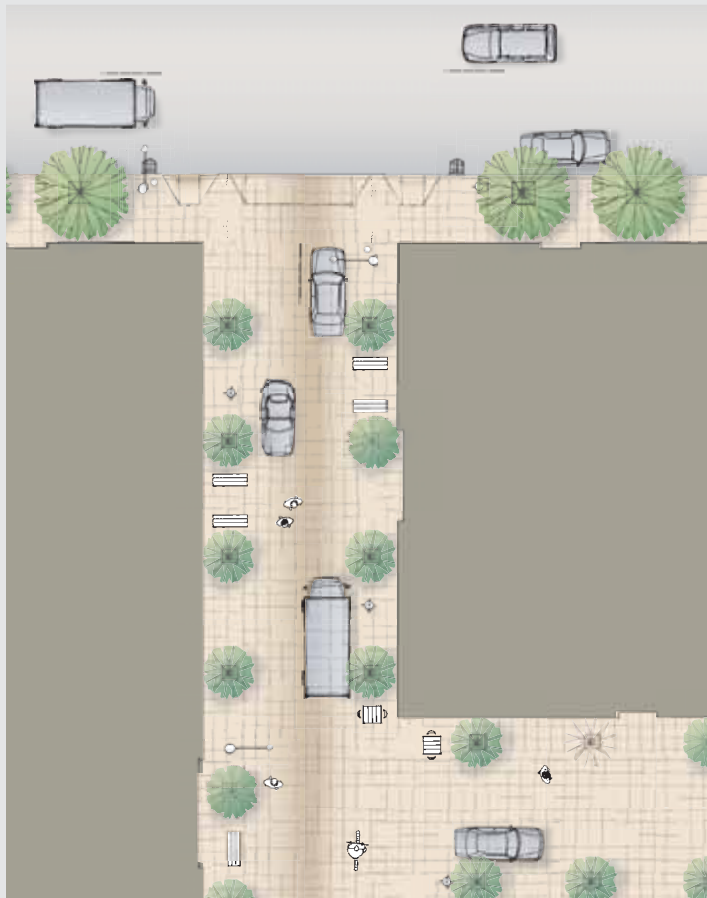

Shared streets should emphasize the shared nature of the space through unified design.

BEST PRACTICE: SHARED STREETS

CAMBRIDGE, MASSACHUSETTS

Over the last 5 years, Cambridge Massachusetts has had a 12 member design committee working with City staff to plan streetscape improvements around Harvard Square. It had been over 20 years since any urban design projects were constructed, and when it came time to repair some crumbling sidewalks the community saw it as an opportunity to overhaul the area due to its high volume of pedestrian traffic and importance in public life. Improvements to date include aesthetic and safety-related projects including attractive lighting and landscaping, widened sidewalks, improved signal timing and crossing conditions at intersections, curb extensions, bike park-

ing and bike route improvements and construction of a number of shared streets. In many cases, high pedestrian volumes and ADA access could not be appropriately accommodated with traffic lanes on historic narrow streets. To address this, many streets were changed to shared streets in order to refocus the space on pedestrian traffic and provide sufficient space for ADA compliant travel. Now cars may use the streets, but pedestrians have the right-of-way on the whole street. Since the first shared streets were completed, the public has been enthusiastic about their success and requested that many more streets be converted.



Pedestrian-Only Streets

On streets with substantial pedestrian activity and thriving commercial land uses, temporary or permanent closure may be considered to encourage pedestrian use of an area by closing the street to vehicles and placing pedestrian amenities, retail displays, and other elements in the street right-of-way.

There are three types of street closure:

- **Temporary closure** - Streets can be closed for short, pre-determined hours of the day or week, such as weekends or evenings, or special occasions, when pedestrians and businesses can take most advantage of the public right-of-way.
- **Pedestrian malls** – Pedestrian malls are permanent closures in areas that are used by high volumes of pedestrians, such as tourist areas and major downtown shopping areas.
- **Transit malls** - Transit malls are a type of street closure that closes the street to private automobiles, but continues to allow use by transit vehicles.

Guidelines

Bollards or landscaping should be placed at intersections of closed streets and perpendicular streets to discourage cars from accidentally turning into closed streets and to remind pedestrians they have reached a transition point and must again be cognizant of automobiles. Other features can also be added, including literal gateways or portals, to define the entries to the closed street.

Permanently closed streets may incorporate formal landscaping or other special landscape treatments, seating, public art, and other pedestrian-supportive elements into the roadway to remind pedestrians that it the space is open to them.

A clear 14' path should be maintained through permanently closed areas for emergency vehicle and delivery access. This path does not need to be straight, but should take the needs of truck maneuverability and required clearances for emergency vehicle operations into consideration. Use of such travel lanes can be managed through the use of removable or automatically retractable bollards.

In transit malls, pavement treatments using material and/or color changes should be used to distinguish the transit lanes from the open pedestrian areas and provide visual contrast, similar to shared streets.

Single-surface treatments should be used for pedestrian malls to remove tripping hazards and obstacles to mobility impaired posed by roadway curbs. Single-surface treatments are appropriate to streets that will be frequently used for temporary closures as well if elements of the streetscape and color define necessary distinctions between the vehicular lanes and pedestrian areas for use during other times. See previous section, Shared Streets.



The 16th Street Transit Mall in Denver provides normal sidewalks for pedestrians to walk along storefronts, dedicated lanes for transit vehicles, and a wide array of amenities and landscaping in the center of the right-of-way, where people can comfortably sit or walk throughout the day.



The beginning of Powell Street, near Market, is a short transit mall, which allows pedestrians full use of the street except when transit vehicles (cable cars) are present.



Belden Lane is a temporary pedestrian mall with cafe seating at the lunch hour



Portland's Festival Streets are closed for only a few days a year for the fall Harvest Festival, however the streets were designed and built to foster easy closure and comfortable pedestrian circulation throughout the entire right-of-way.



Stairs provide opportunities for special pedestrian scale detail and place making.



Stairs are a common component of many hillside streets in San Francisco.

Public Stairs

Public stairs enhance the experience of the natural hillsides that help define San Francisco's distinctive identity and, by nature of being pedestrian only, provide unique urban design opportunities.

Public stairs should be used to provide direct pedestrian routes between hillside locations that might otherwise require a pedestrian to travel a significant distance out of their way to connect by sidewalks. Stairs should also be used to provide an alternative to very steep sidewalks along streets.

Guidelines

The minimum width for a public stairway should be no less than 4 feet.

The riser height and tread depth of each stair should be uniform, with treads no less than 11 inches deep.

- The following formula can be used to determine appropriate tread to riser ratio: $2R + T = 26$ to 27 inches, where R = riser and T = tread.
- Risers should be solid with nosing undersides.

Landings should be provided at frequent intervals to provide rest areas and overlooks, and should provide seating where space allows. The maximum distance between landings should be 12 feet whenever feasible given topography and other existing conditions. The minimum length of the landing should be five feet or equal to the width of the stairway. A continuous handrail that complies with ADA requirements should be provided.

Surface materials should be durable, provide a slip-resistant walking surface—including a contrasting color as per ADA—and be subject to regular inspection and maintenance.

Stair placement, landscaping and lighting should contribute to visibility to and from the stairway, which improves pedestrians safety and security. Pedestrian scale lighting should be provided at landings to improve safety and comfort at night.

Landscaping should be provided adjacent to stairways. Stairways should be designed to prevent the accumulation of water.

Signage should be provided to indicate that the stair is public right-of-way and should inform users where the stair leads, e.g. "Public Stairway to Liberty Street." Signage should alert pedestrians to alternative accessible routes, either along public sidewalks or via ramps where possible.

Technical provisions for accessible features appropriate to public stairs may be found in section 4.7 of ADAAG.



Public stairs may incorporate public art.